

CONNECTION ASSEMBLY INSTRUCTIONS

med 2000.K CAR ALARM ASSEMBLY DIAGRAM

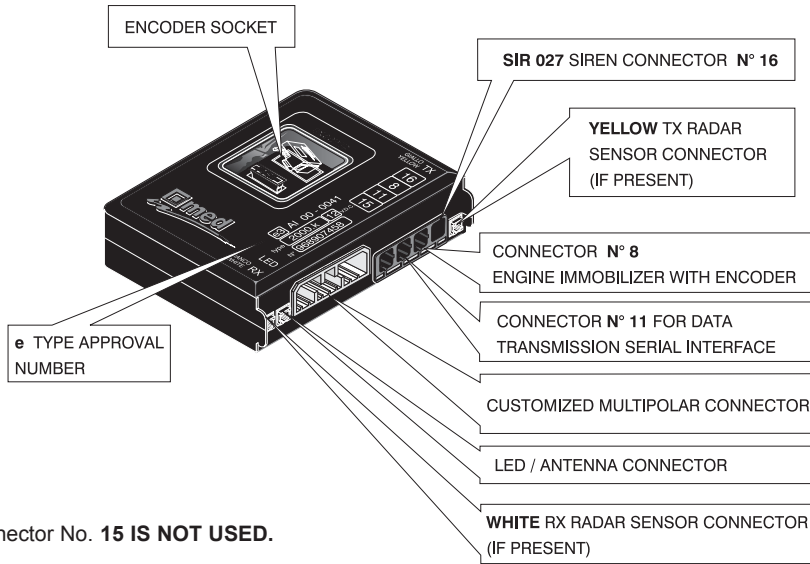

Connector No. 15 IS NOT USED.

FITTING THE LED/ANTENNA

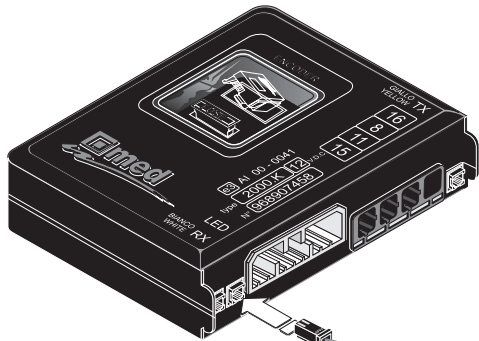

Drill a hole Ø 10 mm. on the fascia in a clearly VISIBLE and accessible position for mounting the LED/ANTENNA.
Connect this cable to the connector marked LED on the alarm unit, keeping it **STRETCHED OUT** and **SEPARATE** from the other wirings for better reception.

LED (red warning light)

CAUTION:
This cable must DEFINITELY NOT be CUT SHORTENED LENGTHENED or REPLACED with non-genuine ones.

COLOUR	MARKED	FUNCTION	CURRENT
BLACK	GND	POWER SUPPLY - EARTH	20 A
RED	[+30]	POWER SUPPLY - LIVE	20 A
ORANGE	[+15]	[+15] PERMANENT DURING STARTING	-
DARK BLUE	MUX	CONTROL FOR DIGITAL CAR ALARM "MUX"	-
LIGHT BLUE	NA	INSTANT N/O INPUT FOR DOOR BUTTONS	-
LIGHT BLUE	NAR	TIME-LAGGED N/O/L INPUT FOR DOOR BUTTONS	-
GREY	1	COMMON CONTACT - UNLOCKING RELAY	10 A
GREY	2	N/C CONTACT - UNLOCKING RELAY	10 A
GREY	3	N/O CONTACT - UNLOCKING RELAY	10 A
GREY	4	COMMON CONTACT - LOCKING RELAY	10 A
GREY	5	N/C CONTACT - LOCKING RELAY	10 A
GREY	6	N/O CONTACT - LOCKING RELAY	10 A
GREY	7	ALARM OUTPUT TO EARTH	700 mA
GREY	8	SIGNAL OF STATUS TO EARTH	700 mA
GREEN	9	LIVE OUTPUT - FOR RIGHT-HAND INDICATOR	10 A
GREEN	10	LIVE OUTPUT - FOR LEFT-HAND INDICATOR	10 A
WHITE	11	COMMON CONTACT - ELECTRICAL BREAK	10 A
WHITE	12	N/C CONTACT - ELECTRICAL BREAK	10 A

The central locking and electrical cut-out relays withstand currents of approximately **10 A** continuous, **30 A** peaks for 10 seconds.

POWER SUPPLY

- **POSITIVE** power supply: **RED** wire marked **[+30]**, to be connected to a reliable point capable of delivering **20 A** (e.g. fuse box or battery). This power supply is also used for the INDICATORS.
- **NEGATIVE** power supply: **BLACK** wire marked **GND**, to be connected to the negative terminal of the battery or to a grounding point on the chassis frame made by the vehicle manufacturer.
- **POSITIVE** ignition key: **ORANGE** wire marked **[+15]** permanent when starting.

CAUTION:

It is recommended to power the alarm unit **ONLY** after completing assembly.

The **[+15]** MUST be connected.

The **med 2000.K** alarm unit needs to be powered at 12 volts.

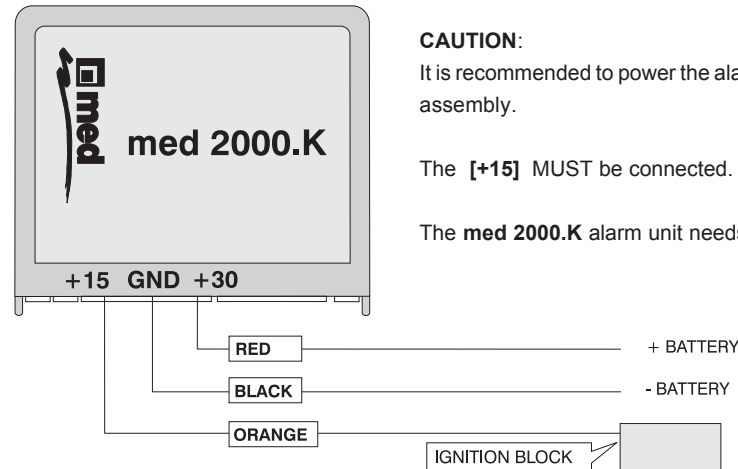

CONNECTION TO CENTRAL LOCKING

WIRING DIAGRAM TO CONTROL ONE OR MORE ADDITIONAL ACTUATORS

A

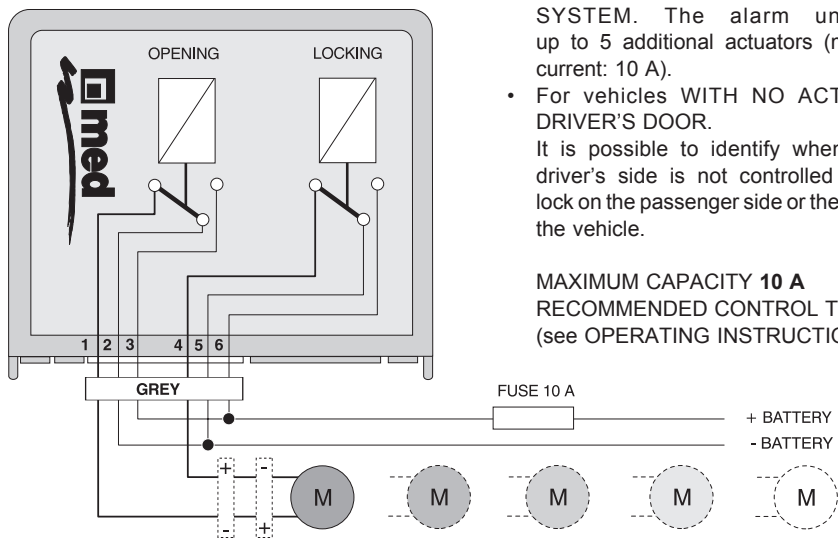

- For vehicles **WITHOUT** CENTRAL LOCKING SYSTEM. The alarm unit can control up to 5 additional actuators (maximum admitted current: 10 A).
- For vehicles **WITH** NO ACTUATOR IN THE DRIVER'S DOOR. It is possible to identify when the lock on the driver's side is not controlled by acting on the lock on the passenger side or the push-button inside the vehicle.

MAXIMUM CAPACITY **10 A**
 RECOMMENDED CONTROL TIME **1.25 sec.**
 (see OPERATING INSTRUCTIONS)

B

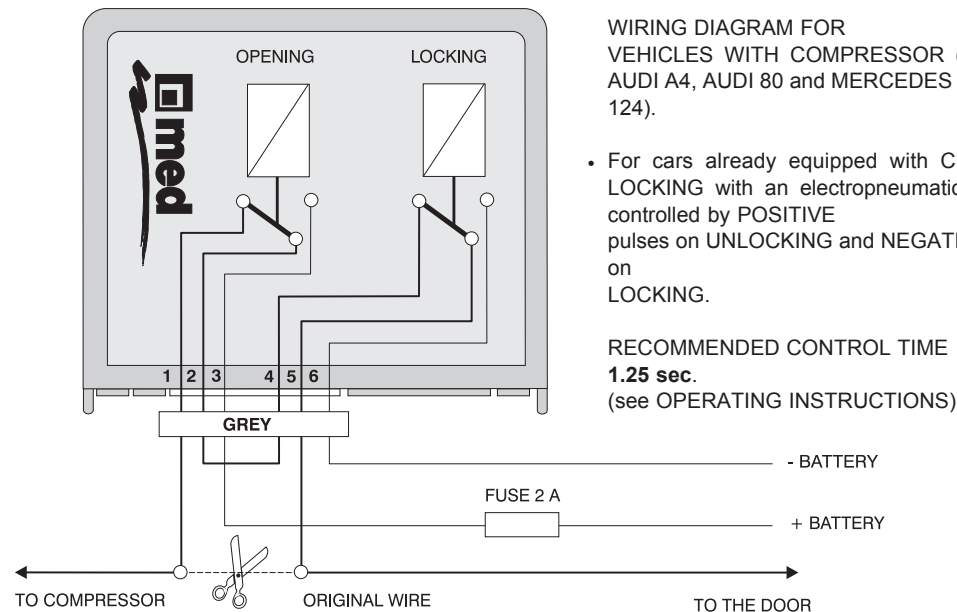

WIRING DIAGRAM FOR VEHICLES WITH COMPRESSOR (such as AUDI A4, AUDI 80 and MERCEDES series W 124).

- For cars already equipped with CENTRAL LOCKING with an electropneumatic system controlled by POSITIVE pulses on UNLOCKING and NEGATIVE ones on LOCKING.

RECOMMENDED CONTROL TIME **1.25 sec.**
 (see OPERATING INSTRUCTIONS)

- For cars already equipped with CENTRAL LOCKING controlled with **NEGATIVE** controls.

C

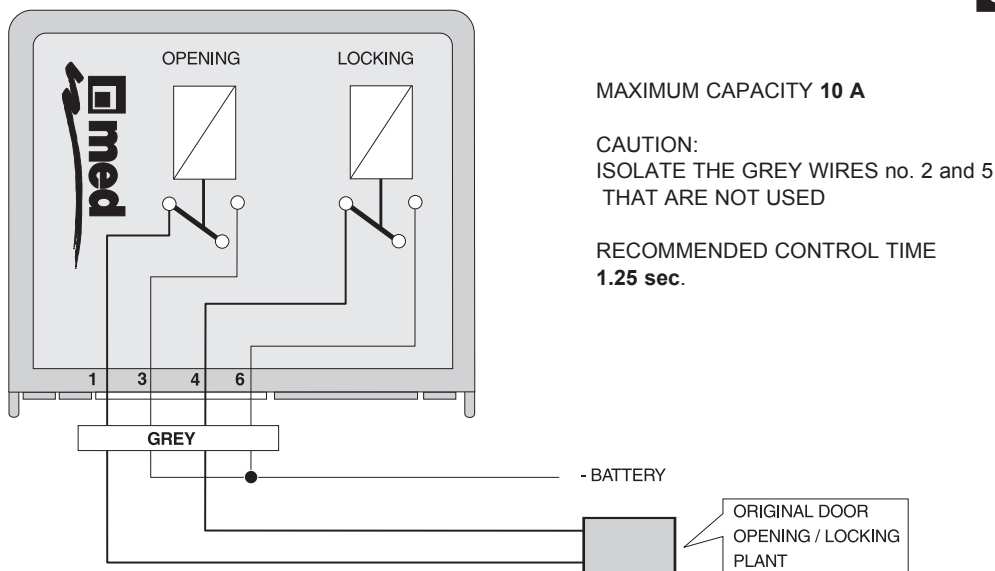

MAXIMUM CAPACITY **10 A**

CAUTION:
 ISOLATE THE GREY WIRES no. 2 and 5
 THAT ARE NOT USED

RECOMMENDED CONTROL TIME **1.25 sec.**

D

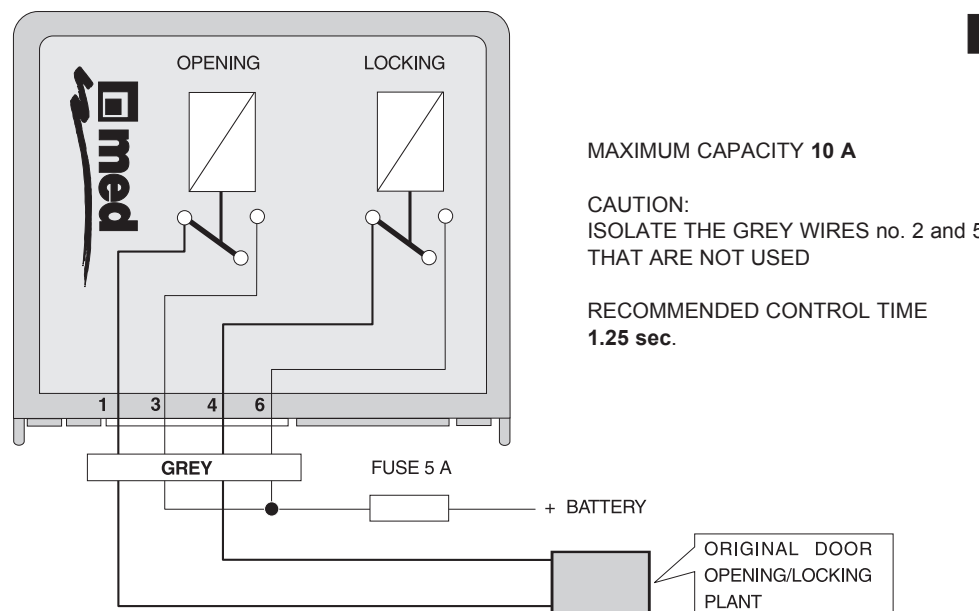

MAXIMUM CAPACITY **10 A**

CAUTION:
 ISOLATE THE GREY WIRES no. 2 and 5
 THAT ARE NOT USED

RECOMMENDED CONTROL TIME **1.25 sec.**

PUSH-BUTTON CONNECTIONS

The alarm unit has 2 different inputs for connecting NORMALLY OPEN push-buttons to EARTH that are only differentiated upon SYSTEM ACTIVATION:

N/O - INSTANTANEOUS: the input is immediately RECOGNIZED by the alarm unit

N/O/L - TIME-LAGGED: the input is RECOGNIZED by the alarm unit after approximately 30 seconds.

IT IS RECOMMENDED to ALWAYS use the **N/O** input that provides the rejection signal on activating the system with a door open (see OPERATING INSTRUCTIONS).

The **N/O/L** input should ONLY be used in the case of a time-lagged courtesy light with return to earth if a diode is not appropriately inserted (Fig. C), or with special systems, such as the ALFA ROMEO 164 that has normally closed push-buttons on the doors (Fig. E). **N.B.** Push-buttons of doors, bonnet and boot must **ALWAYS ALL BE CONNECTED**.

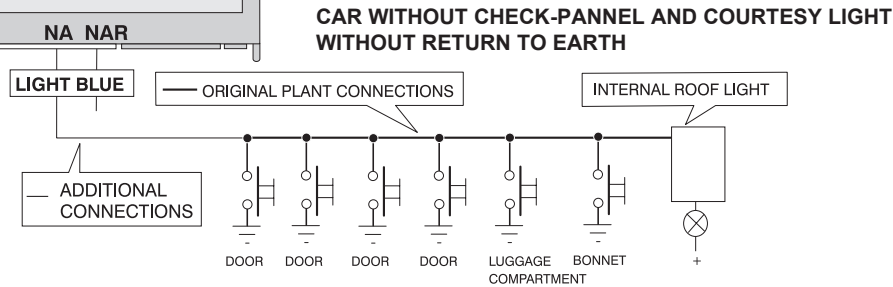
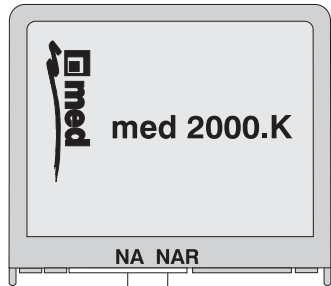

A

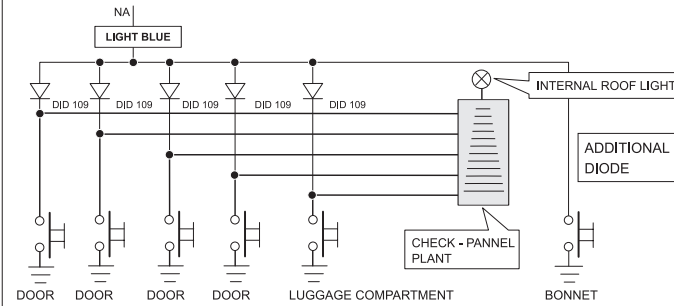

B

CAR WITH COURTESY LIGHT CONTROLLED BY ORIGINAL CHECK-PANNEL CONTROL UNIT

It is recommended to use the **DID 509** module with 5 pre-wired diodes

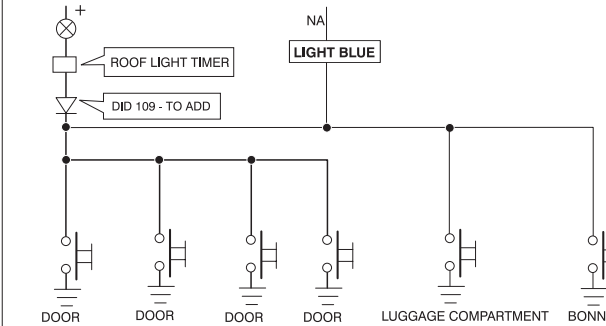

C

CAR WITH TIMED COURTESY LIGHT, WITH RETURN TO EARTH AND DIODE FOR UNCOUPLING

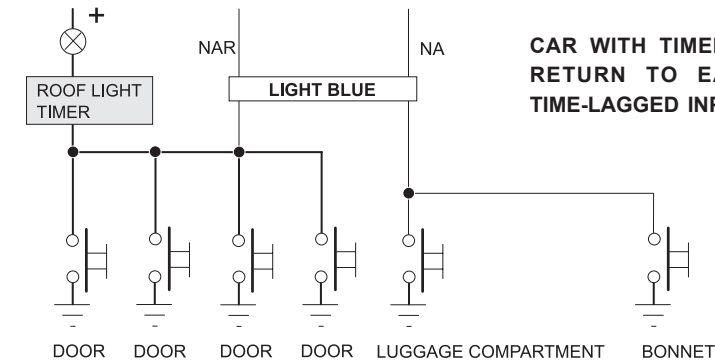

D

CAR WITH TIMED COURTESY LIGHT, WITH RETURN TO EARTH USING THE N/O/L TIME-LAGGED INPUT INSTEAD OF THE DIODE

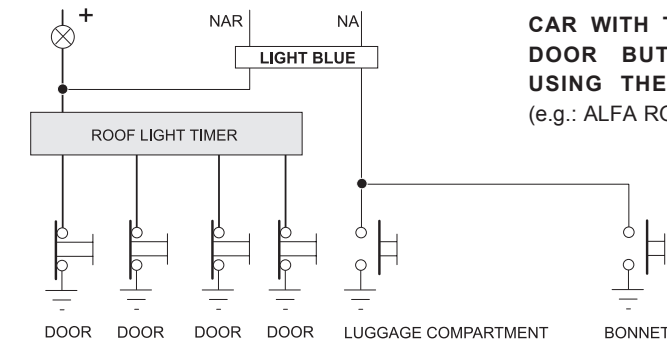

E

CAR WITH TIMED COURTESY LIGHT AND DOOR BUTTONS WITH N/C BUTTONS USING THE TIME-LAGGED N/O/L INPUT (e.g.: ALFA ROMEO 164).

CONNECTION TO ANTI-LIFTING SENSOR SEN 077-02

The **SEN 077-02** has to be positioned horizontally, in an area protected against infiltration of liquids or condensation, following the diagram shown:

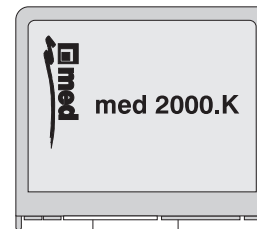

CAUTION: **SEN 077-02** MUST NOT BE POWERED when the vehicle is travelling.

TO POSITION THE **SEN 077-02** SEE THE SPECIFIC INSTRUCTIONS. The status output has to be fixed - *standard setting*

If it is necessary to have the timed status output, control **SEN 077.02** with the relay for key positive, as indicated in its instructions.

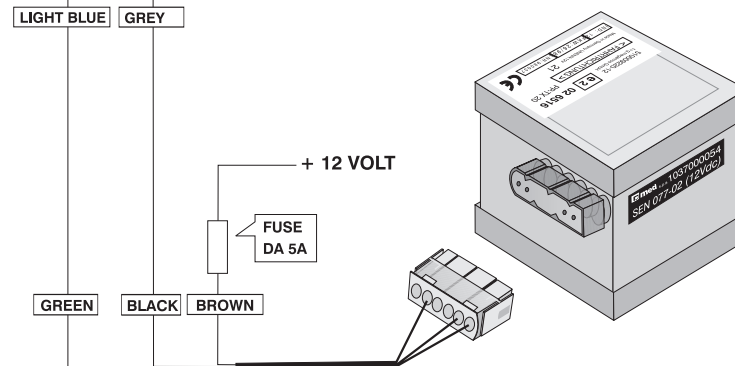

INDICATOR CONTROL

The **GREEN** wires marked **no. 9** and **no. 10** supply a **POSITIVE** control directly (max. 10 A per channel) to control the INDICATORS.

The **RED[+30]** wire is the same one as for the alarm unit supply.

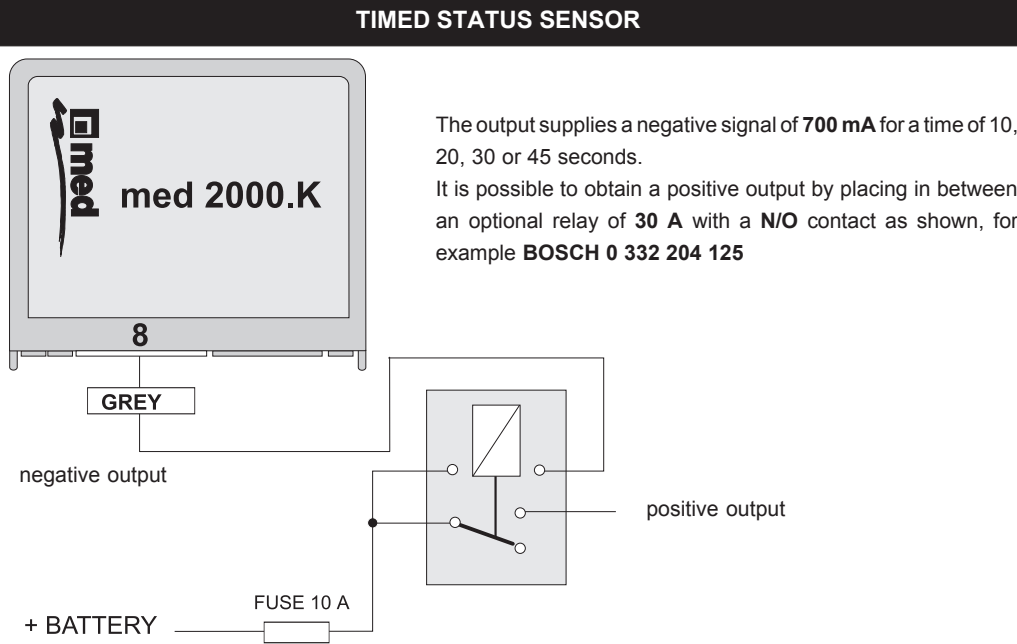
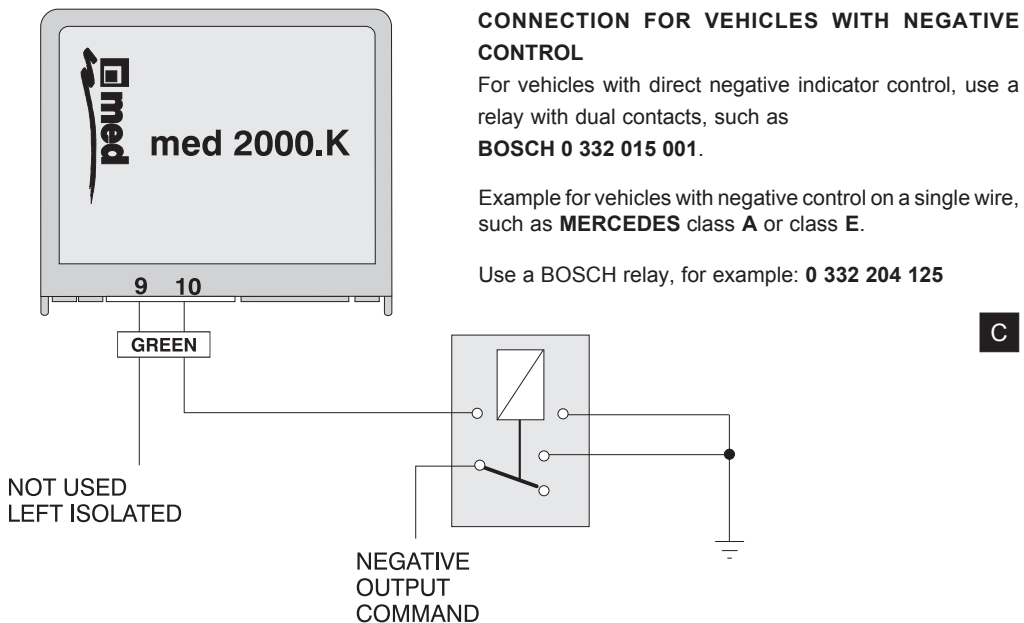
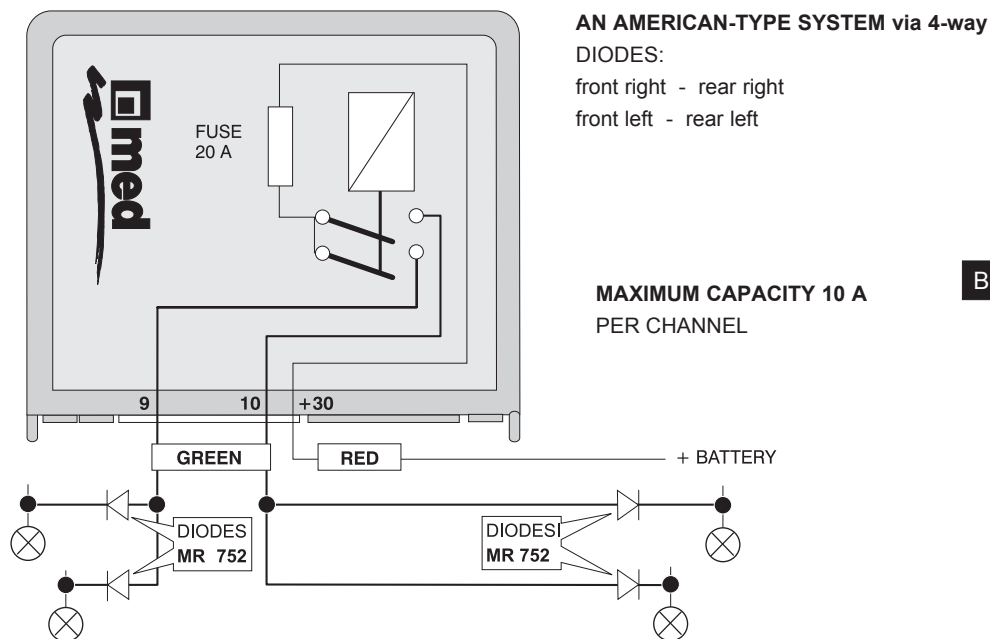
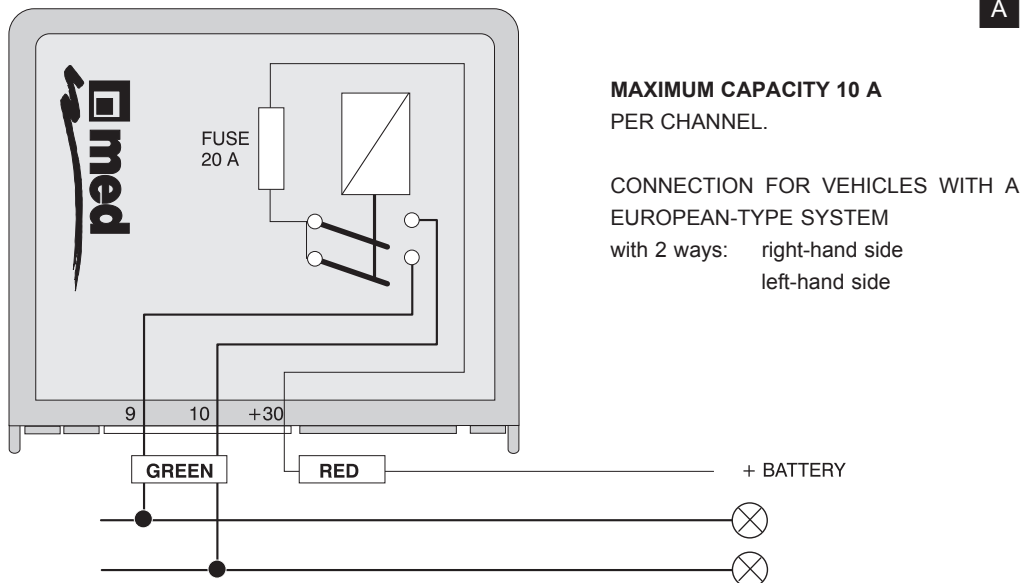

CONNECTION TO THE SIREN SIR 027

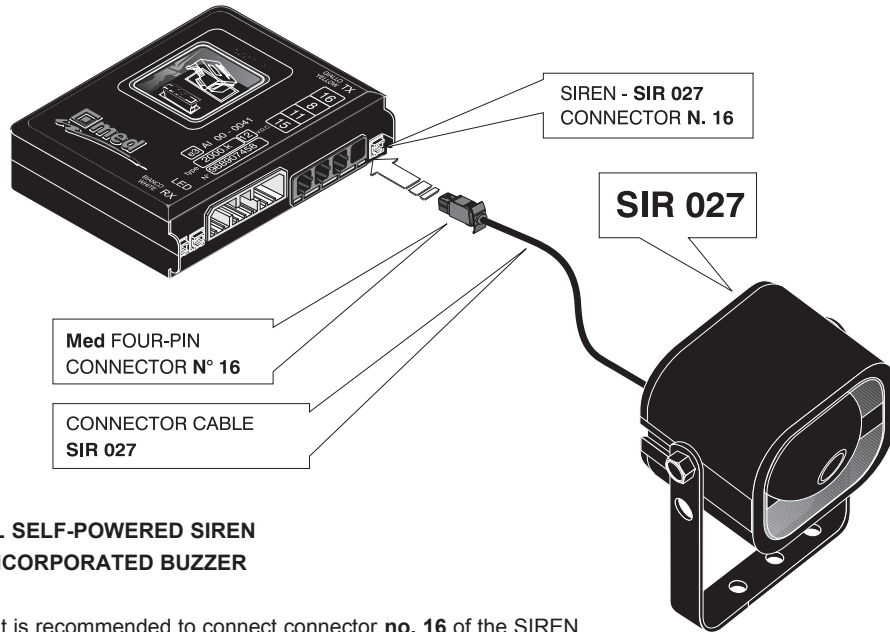

DIGITAL SELF-POWERED SIREN WITH INCORPORATED BUZZER

N.B. It is recommended to connect connector **no. 16** of the SIREN to the alarm unit only **AFTER** first **TESTING** the system.

ALARM OUTPUT

The negative alarm OUTPUT, electronically protected with a maximum current of **700 mA**, programmable between **intermittent** (standard) or **fixed**, makes it possible via an optional relay with **N/O (Normally Open)** contact to control the vehicle's horn (**INTERMITTENT** for the duration of the alarm cycle) or one or more additional sirens (**INTERMITTENT** or **FIXED**).Apply the right diagram from the following:

CONNECTION TO THE VEHICLE'S HORN WITH POSITIVE CONTROL

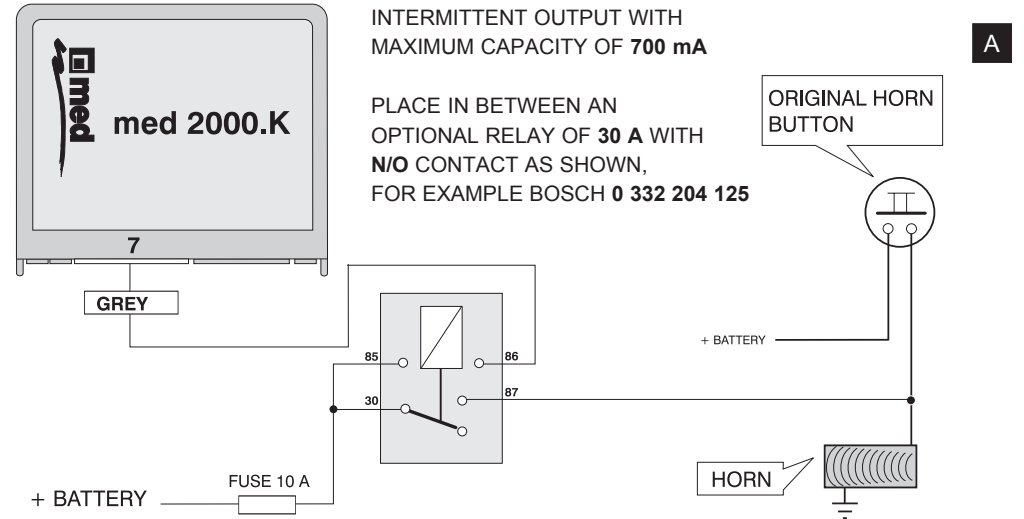

CONNECTION TO THE VEHICLE'S HORN WITH NEGATIVE CONTROL

INTERMITTENT OUTPUT WITH MAXIMUM CAPACITY OF **700 mA**.
PLACE IN BETWEEN AN OPTIONAL RELAY OF **30 A** WITH **N/O CONTACT** AS SHOWN, FOR EXAMPLE **BOSCH 0 332 204 125**.

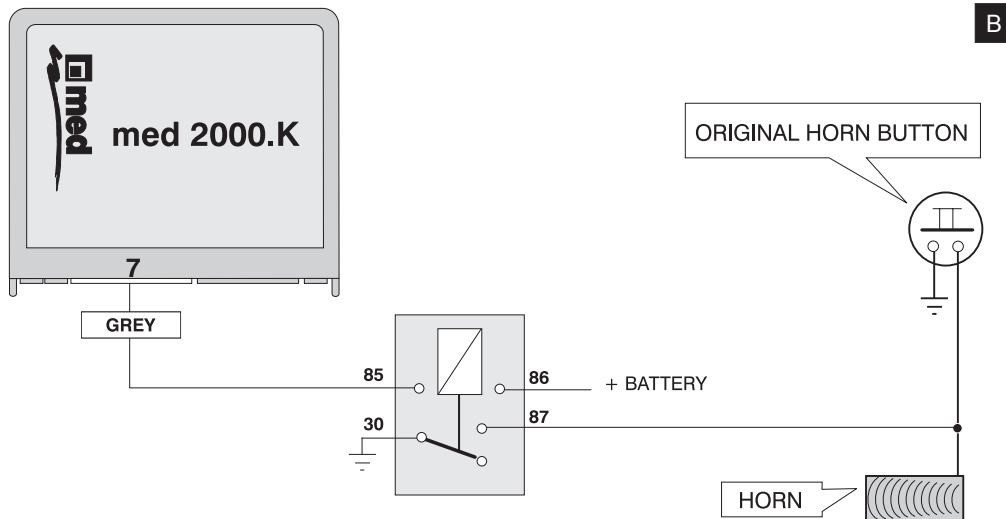

CONNECTION TO THE VEHICLE'S HORN WITH NEGATIVE CONTROL AND KEY POSITIVE [+15].

INTERMITTENT OUTPUT WITH MAXIMUM CAPACITY OF **700 mA**.
PLACE IN BETWEEN AN OPTIONAL RELAY OF **30 A** WITH **N/O CONTACT** AS SHOWN, FOR EXAMPLE **BOSCH 0 332 204 125**.

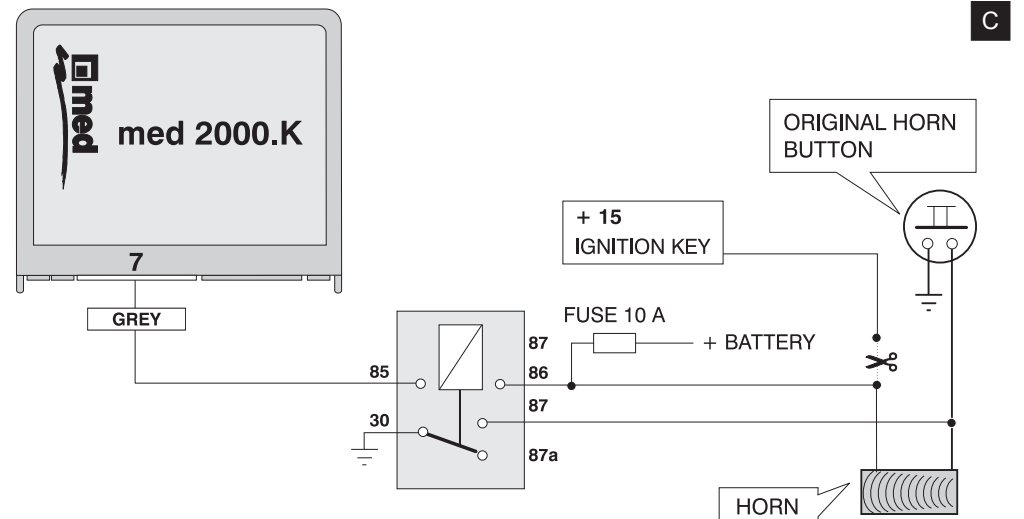

IMMOBILIZER PRIMARY PROTECTION

The alarm unit is fitted for controlling all types of 12 V **med** IMMOBILIZER in the car line:

- A. Version with ENCODER: **med 57 - med 58** or **DUP 011**
- B. Version with DIGITAL control on line "MUX": **med 30.1 - med 30.2D - med 58.XD**

A. CONNECTION WITH **med** IMMOBILIZER EQUIPPED WITH ENCODER.

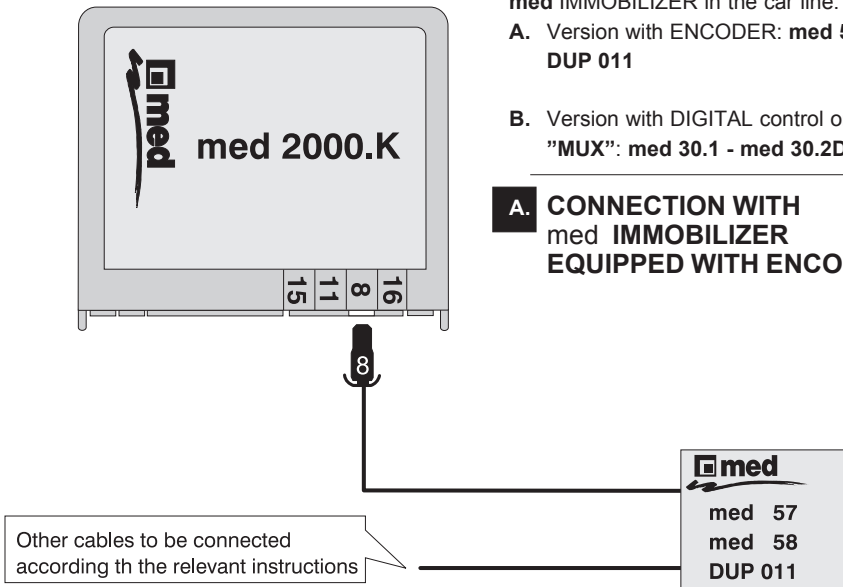

1. Insert the IMMOBILIZER ENCODER into the socket on the top of the alarm unit, protecting it with the adhesive LABEL already affixed.
2. Insert the four-pole connector **no.8** of the IMMOBILIZER into the SOCKET marked **no.8** on the front of the alarm unit.
3. Connect the IMMOBILIZER power supply cables and the GREEN wire following the specific car alarm instructions.

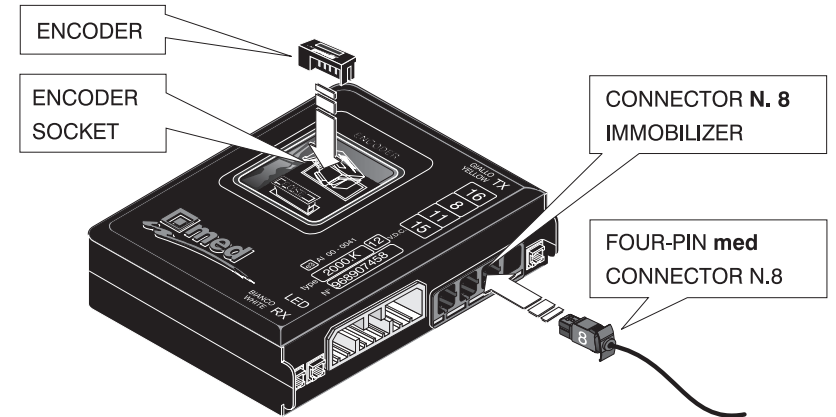

CAUTION:
The ELECTRONIC KEYS and KEY SOCKET that may be supplied with the IMMOBILIZER will not be used.

B. CONNECTION WITH DIGITAL IMMOBILIZER SERIES **med 30 - med 58.XD**

Connect the IMMOBILIZER to the **DARK BLUE** wire marked "MUX", following the SPECIFIC CAR ALARM ASSEMBLY AND CONNECTION INSTRUCTIONS.

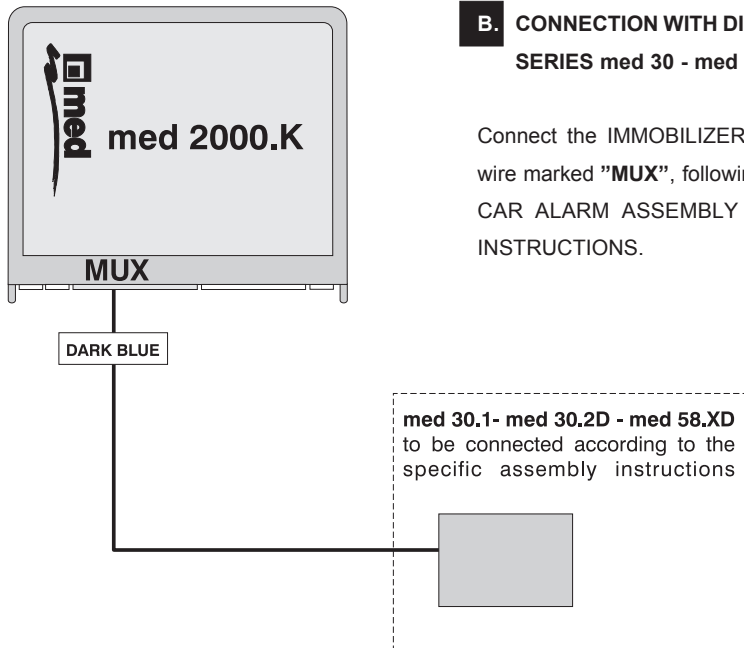

CONNECTION TO THE WINDOW WINDER MODULE AZC 130

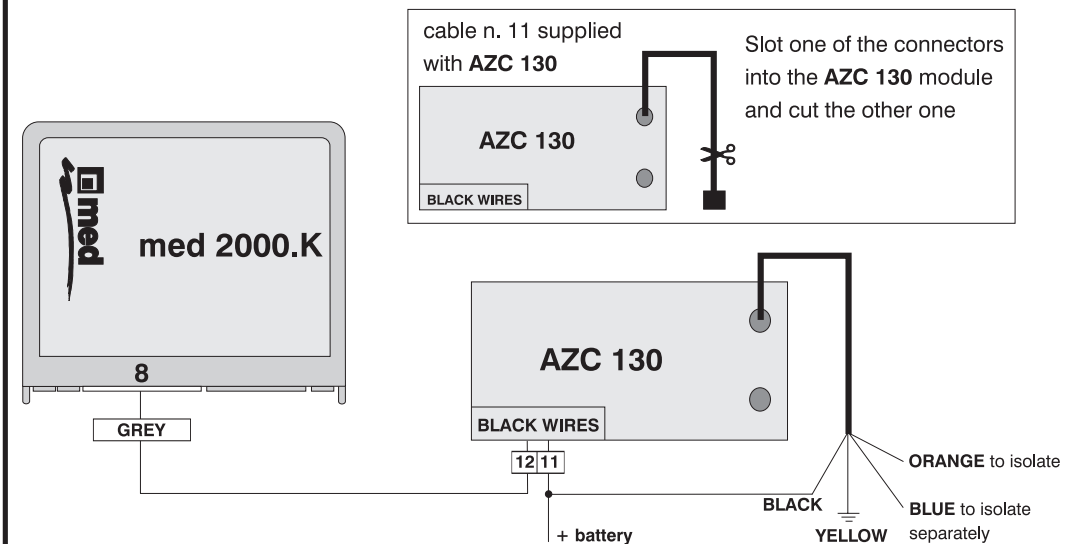

Complete connections of the **AZC 130** as per the relevant instructions.

ADDITIONAL ELECTRICAL BREAK CONNECTION

The RELAY has a **N/C** (Normally Closed) contact with capacity **10 A - (30 A for 10 seconds)** and two **WHITE** wires for the connection marked **no.11** and **no.12**. The OUTPUT can provide the control with **POSITIVE** or **NEGATIVE** polarity.

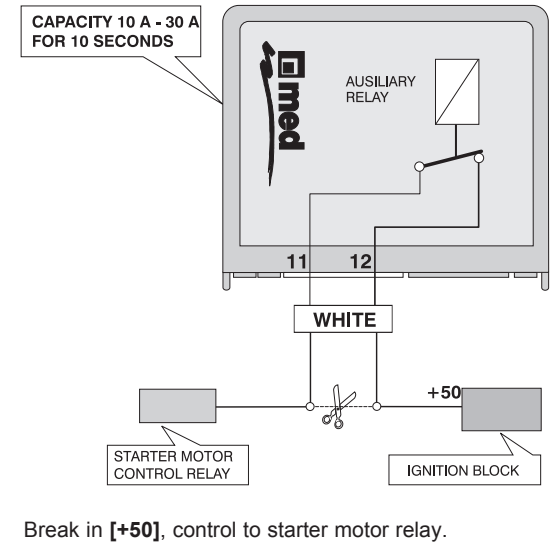
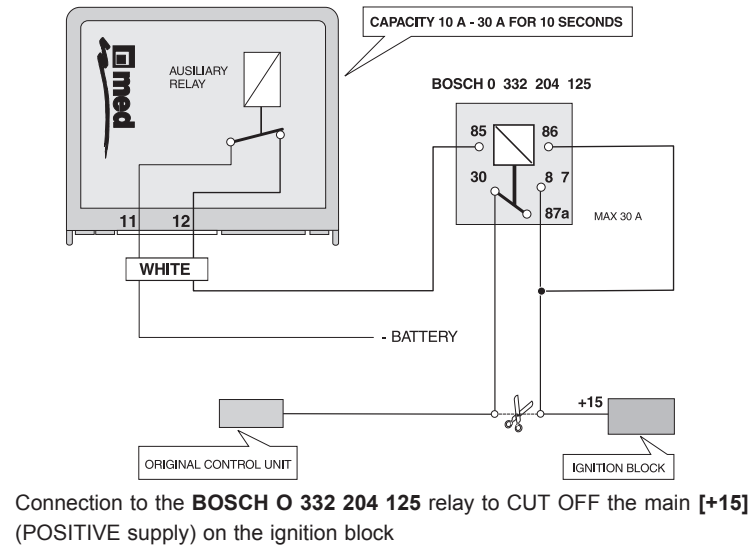
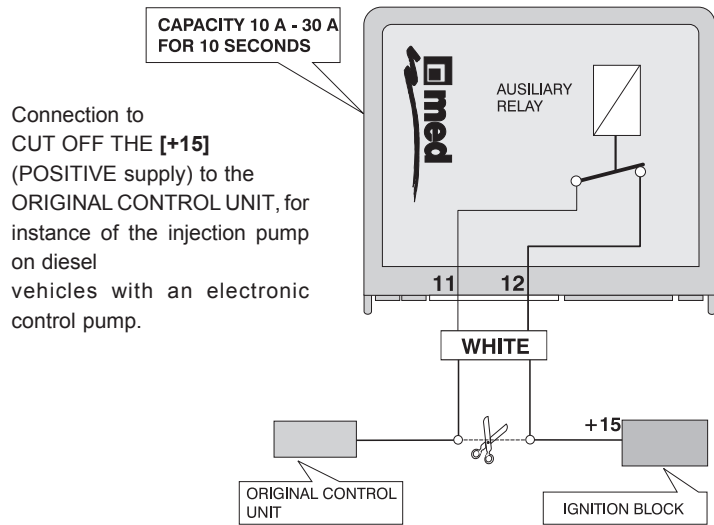

24 VOLT VEHICLE CONNECTION

The **med 2000.K** alarm unit must be powered at 12 volts with a suitable **med** power supply, such as the **24 V KIT**. The indicators need to be uncoupled, using a suitable relay with a 12 Volt coil and dual **N/O** (Normally Open) contacts, such as: **BOSCH 0 332 015 001**

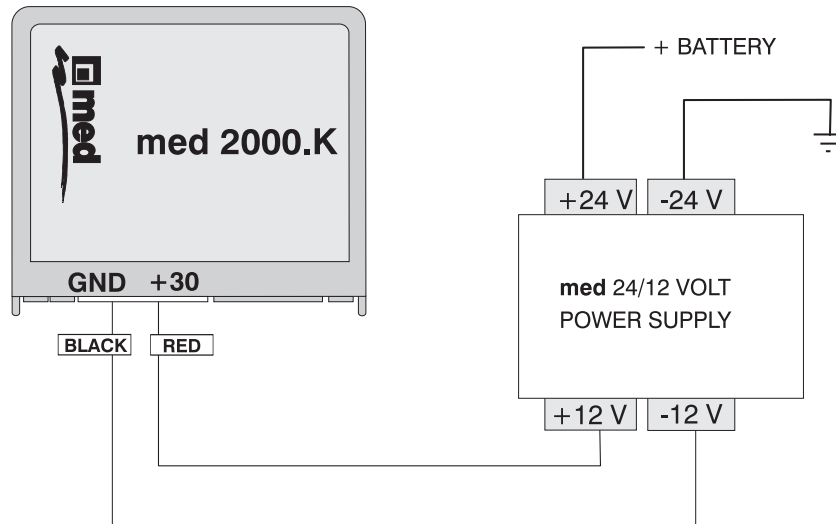

The other inputs/outputs of the **med 2000.K** alarm unit can operate at 24 Volts, for instance **+15, N/O, N/O/L**, electrical breaks.

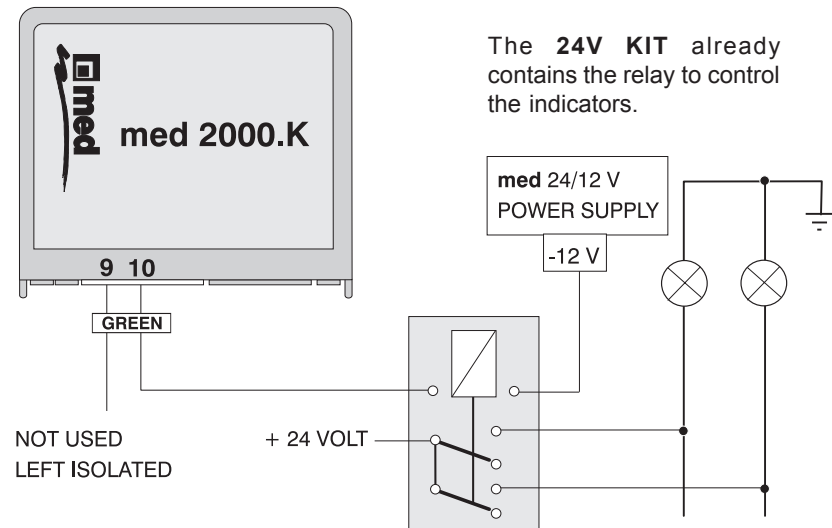

CAUTION: It is recommended to power the alarm unit **ONLY** after completing assembly

CAUTION:

On "ADR" vehicles (suitable for transporting hazardous goods) the system must be made according to specific requirements. Call **med** Technical Service.

CONNECTING THE RADAR SENSORS MTR 2000

N.B. If the RADAR is activated with the ANTI-BLINDING and ANTI-MASKING functions, it is ABSOLUTELY necessary to combine it with the RADAR SENSORS.

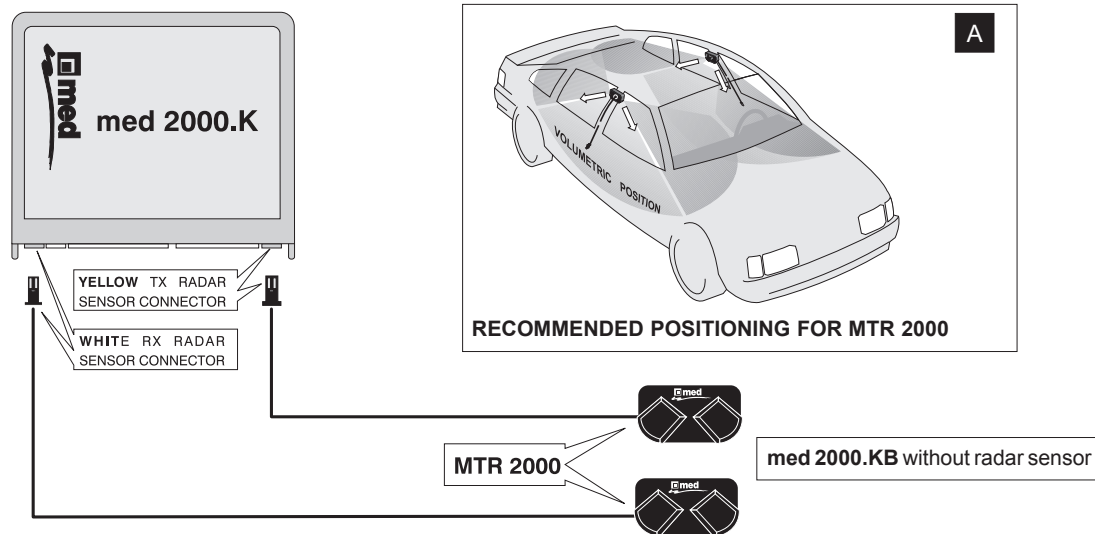

RECOMMENDED POSITION FOR CORRECT ASSEMBLY

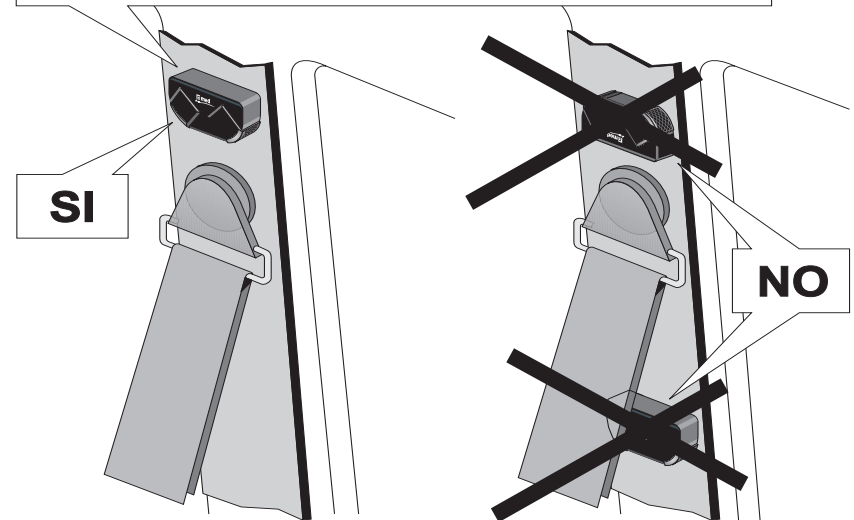

MOUNTING ON UPRIGHT TRIM

1. Take off the upright trim.
2. Drill the trim using the supporting metal plate as a template. See figure.
3. Secure the supporting metal plate.
4. Insert the cable and snap shut the sensor.
5. Fit the trim back onto the upright.

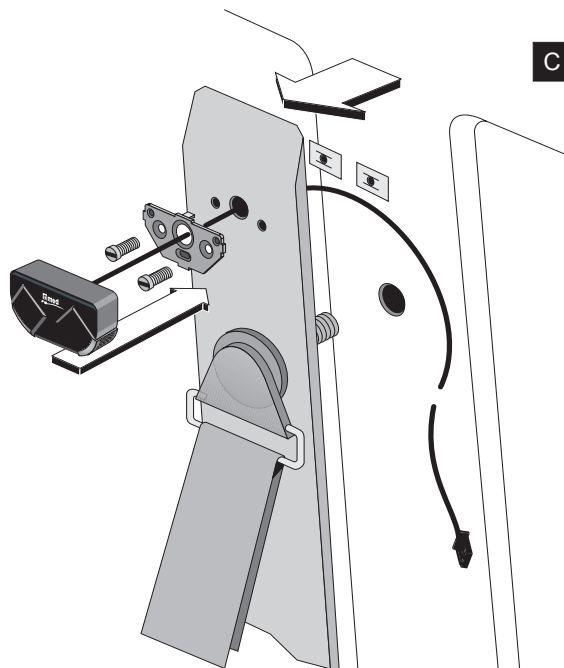

MOUNTING ON THE UPRIGHT WITH TRIM ADHERING TO THE SHEET METAL

1. Drill the upright using the supporting metal plate as a template: see figure. For the two self-tapping fixing screws, supplied in the package, a hole of $\varnothing 2,5$ mm is suitable.
2. Secure the supporting metal plate.
3. Insert the cable and snap shut.

