

**USER'S GUIDE
ENGLISH**

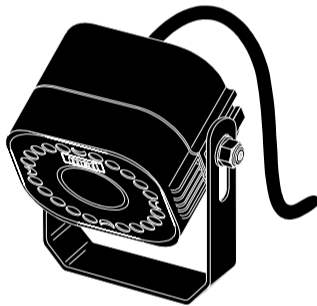

MED 6000.LW



SIR 050



CHD 400

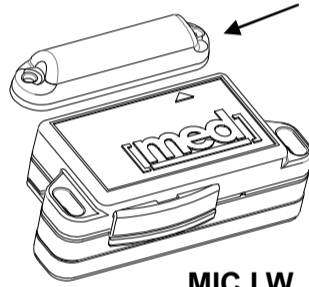

MIC LW
MAGNET

MIC LW



MIC MEC LW
BUTTON

MIC MEC LW

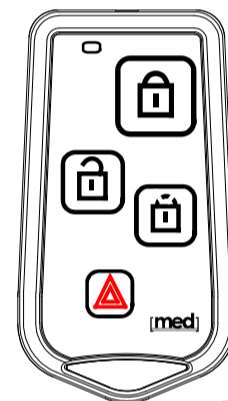

TX PAR LW

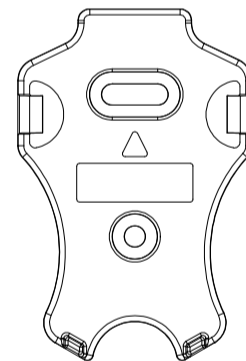

TX PAR LW
SUPPORT

**MODULAR ALARM CENTRAL UNIT
WITH BUILT-IN RECEIVER FOR WIRELESS MODULES**

NEW REMOTE CONTROL MED TX PAR LW

COMPANY
WITH QUALITY SYSTEM
CERTIFIED BY
BUREAU VERITAS
ISO 9001:2008

A.E.B. S.p.A. a socio unico / a single member Company - Via dell'Industria, 20
42025 - Corte Tegge - Cavriago (RE) - Italy
med è un marchio / is a trademark of A.E.B. S.p.A. www.medautomotive.it
e-mail: service@medautomotive.it



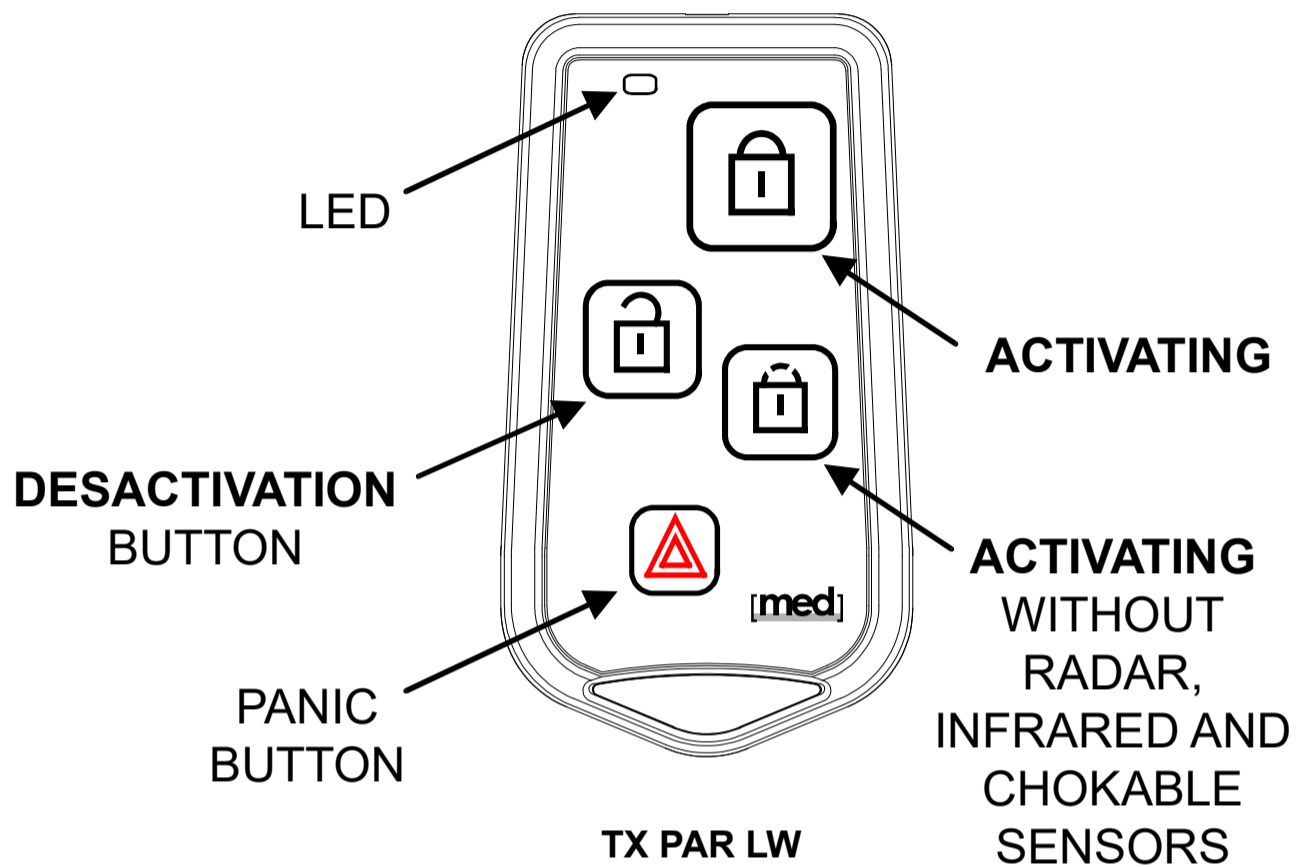

QUICK WORKING INSTRUCTIONS

ACTIVATING THE SYSTEM VIA REMOTE CONTROL WITH RADAR, INFRARED AND CHOKABLE SENSORS AND WINDOW CLOSING ENABLED:

Press **1 time** the button on the remote control TX PAR LW with the symbol  once.

Confirmation: **2** direction indicators **flashings**, **2 two-tone signals** of the buzzer, doors locking, windows closing, **LED lit fixed** (red pilot lamp), then flashing with active ultrasonic sensor.

WARNING: **3 flashings**, **3 two-tone signals**, doors locking, windows closing, **LED immediately flashing** indicate the activation without ultrasonic sensor (definitive cutting out).

3 flashings, **3 two-tone signals**, doors locking, window closing, **LED lit steady and then blinking** mean that the system is activated with exclusion of the reading function of the buttons detected by the LIGHT BLUE/WHITE wire.

WITHOUT RADAR, INFRARED AND CHOKABLE SENSORS AND WINDOW CLOSING:

Press **1 time** the button on the remote control TX PAR LW with the symbol  once:

Confirmation: **4 short flashings** of the direction indicators, **4 two-tone signals** of the buzzer, doors locking and LED immediately flashing.

The cutting out is valid till the following activation.

SYSTEM DESACTIVATION

Press **1 time** the button of the TX PAR LW with the symbol  once or **2 times** in fast sequence (only for those cars where the double manual control opens the driver's door first, and then the passengers' ones).

Confirmation: **Long blinking** of the turn signals, **1 long buzzer signal**, doors opening, LED off (on some vehicles it may be on even if the doors, connected to the control unit on the LIGHT BLUE/WHITE wire).

WARNING:

The direction indicators can be connected to give the optical signals when the system alarms. In some vehicles they can give also the "service signals" and the system "activation / desactivation" signals in addition to the LED and the **SIR 050** or **SIR 050.NA** buzzer.

If any anomalies or alarms occurred, **the first alarm** is shown by some additional signalings (BEEPS) of the siren and by some LED flashings:

- 2** Contact key [+15] ON.
 - 3** Ultrasonic sensor (it detects all kind of intrusions in the vehicle).
 - 4** Opening the doors, bonnet or boot (connected to the LIGHT BLUE/WHITE wire).
 - 5** Anti-tampering of the ultrasonic sensor (anti-blinding / anti-masking).
 - 6** Self-diagnosis of the system.
 - 8** Activating the system with door, bonnet and boot buttons, connected to the LIGHT BLUE/WHITE wire, excluded and configured as the instantaneous input, after refusal due to an open door.
 - 9** Opening the doors, windows and storage compartments detected by wireless contacts MIC LW, MIC MEC LW.
 - 10** Opening the doors, windows, storage compartments detected by chokable wireless contacts: MIC LW, MIC MEC LW, infrared sensors SEN INFRA LW, SEN INFRA 360 LW.
- **The alarm memory is repeated if the system is activated and desactivated without turning the contact key on [+15] ON.**
It's cancelled only by turning the contact key [+15] ON.
 - The PANIC function does not generate an alarm memory.

To simplify the use of the system, we always suggest the pairing of the electronic key CHD 400 (allowing the system activation / deactivation without the remote control and the vehicle start). The system is completed by the **SIR 050 SIREN** equipped with the internal buzzer to help in the use of the system, such as the activation / deactivation, the warning signalings, the alarm memories, etc.

We offer a complete range of accessories designed specifically to be paired with this alarm control unit, which prove useful to complete the vehicle's protection system, such as the following for example: wireless sensors with magnetic contact MIC LW or mechanical contact MIC MEC LW for protecting doors, windows and storage compartments; infrared sensors SEN INFRA LW (mounted on sides) or SEN INFRA 360 LW (mounted on internal roof); auxiliary acoustic indicators and the telephone alarm repeater MED-CALL, the satellite protection systems controlled by both the Control Centre and also self-sufficiently by the vehicle owner.

Ask your MED installer for more.

WARNING:

- These instructions are referred to the system completely installed.
- The other opening parts will also be indicated as doors, for example: hatch doors, windows, storage compartments, bonnet, boot, etc.
The other versions are also indicated as **MED 6000.LW**.
- The installer has to give to the vehicle owner the **PIN CARD**, **THESE USER'S GUIDE** and the **INSTALLATION CERTIFICATE** duly filled out and signed, that is valid as product warranty (to keep on board).
- The central unit has to be installed by skilled personnel.
- Some functions may exclude others.
Some depend directly on the equipment of the vehicle and on the accessories installed.
- The maximum transmission range of the wireless sensors (roughly 10 meters) is reduced in the presence of strong radiofrequency disturbance and also if the built-in battery should run low.
- Follow the instructions below to replace the battery.
- A.E.B. S.p.A. declines all responsibility and suspends the warranty in case of any inappropriate use of the product, in case of tampering or pairing with inappropriate devices.
- Position the control unit and the wireless sensors inside the vehicle, away from heat sources and protected against the infiltration of liquids or condensate; the wires must lead up to the control unit from below.
- A.E.B. S.p.A. reserves the right to bring any kind of improvements without previous notice.
- The **MED 7000.LW** can be installed in **24 Vdc** vehicles with the **KIT 24V** potential divider.

DENIAL ON ACTIVATION

- With the ignition key turned on, all the remote controls and the electronic key are ignored.
- **3 Beeps and 3 blinks** of the LED indicate that the door, bonnet or boot is open if connected to the **light blue/white** wire configured as **Instantaneous** input.
 - Close the door and re-activate the system the system will activate it self and exclude the control function on this line, also pointing out the condition when de-activating with 8 beeps of alarm memory.
 - With the input configured as **DELAYED**, if the door is not closed the system **ACTIVATES** and then runs an alarm cycle after the set delayed time has elapsed (30 or 50 seconds).
In this case the input remains active all the time.
- **5 BEEPS and 5 flashings** of the LED mean that the system is **OUT OF ORDER**.
PROGRAM the system to activate it again.

PANIC FUNCTION

Using the transmitter **TX PAR LW** you can activate an alarm cycle with the siren, turn signals and supplementary warning devices in the case of a dangerous situation.

With the ignition key turned off, press the button of the **TX PAR LW** with the symbol  for **2 / 3** seconds consecutively until the alarm cycle starts. The alarm is interrupted by pressing the panic button or the de-activation button of the **TX PAR LW** or using the electronic key **CHD 400**.

THE FOLLOWING INSTRUCTIONS ALLOW A DEEPER KNOWLEDGE OF THE SYSTEM

ACTIVATION / DESACTIVATION SYSTEMS

REMOTE CONTROL TX PAR LW

The new TX PAR LW unit has **4 buttons**: complete activation of the system, partial activation of just the perimeter protection MIC LW and MIC MEC LW (without volumetric sensors, or infrared sensors, or MIC LW or MIC MEC LW that can be choked), de-activation and PANIC FUNCTION. They are antiscanner, ROLLING CODE and self-learning. Those in the box are ready to use. It is possible to use up to 4 pieces simultaneously, cancel the lost and pair some other, new ones (please ask your installer). It has a replaceable lithium battery CR 2032.

CHD 400 ELECTRONIC KEY

It is used to completely activate the system, to partially activate just the perimeter protection MIC LW and MIC MEC LW (without volumetric sensors, infrared sensors, MIC LW or MIC MEC LW that can be choked by means of the LED/BUTTON) and to de-activate the system.

This is antiscanner, ROLLING CODE and self-learning. This is in the box is ready to use. It is possible to use up to 2 pieces simultaneously, cancel the lost and pair some other, new ones.

CHD 400 ELECTRONIC KEY OPERATION

Put and press the key on its key socket (the two metallic parts have to come in contact).

During the "contact" the LED switches on flashing quickly.

SYSTEM ACTIVATION BY THE CHD 400 ELECTRONIC KEY

Press it on its socket: the LED "vibrates" lightly, then detaching it, it remains lit steady and the buzzer sounds continuously, which ends with the usual indication that the system is activated, after approximately **15 seconds**.

- The procedure is stopped by placing the key on its socket again, by switching the vehicle ignition key on or using a **TX PAR LW** remote control.
- The system activates completely but does not pilot door closing.

Close the doors with the vehicle's original system (original remote control or key)

CHOKED ACTIVATION OF THE SYSTEM BY MEANS OF THE CHD 400

1) Turn the ignition key OFF or, with the ignition key OFF, open a door connected to the LIGHT BLUE/WHITE wire; while the LED is lit steady, press the button of the LED right down until the two-tone acoustic confirmation signal is given (LED OFF with button pressed).

2) Press the electronic key on its socket: the LED switches on and "vibrates" lightly; take it off the socket and the LED remains lit steady and the buzzer sounds continuously, which ends with the usual indication that the system is partially activated with just the perimeter protection MIC LW and MIC MEC LW (without volumetric sensors, infrared sensors, MIC LW or MIC MEC LW choked sensors), after approximately **15 seconds**.

- The procedure is stopped by placing the key on its socket again, by switching the vehicle ignition key on or using a **TX PAR LW** remote control.
- The system activates completely but does not pilot door closing.

Close the doors with the vehicle's original system (original remote control or key).

SYSTEM DESACTIVATION BY THE CHD 400 ELECTRONIC KEY

Open the door using the original vehicle's system.

- If the system was activated by the MED remote control, the system alarms.
- If it was activated using the **CHD 400** key, it is possible to deactivate it within 10 seconds avoiding the alarm from the buttons, the ultrasonic sensor and the additional modules.
- When turning the ignition key **[+15] ON**, the system alarms immediately.

Press the key on its key socket: the LED starts "vibrating" slightly, followed by the doors opening with the usual system deactivation signaling, followed by the "alarm memory", if any alarms or anomalies have occurred.

PIN CARD

It is the card supplied in the box, showing the serial number of the central unit and the EMERGENCY CODE, with the relevant use procedure. It allows the system desactivation without remote control or electronic key.

It allows the **CHD 400** electronic keys and **TX PAR LW** self-learning, either to add some others or to cancel the lost ones. Duplicates available on request at the installer's place giving him the "serial number" of the central unit.

PAIRING / CUTTING OUT OF THE TX PAR LW REMOTE CONTROLS

- 1) With the system in off position, enter the EMERGENCY CODE as shown on the PIN CARD.
- 2) When the confirmation BEEPS end and the LED is switched on fixed again, within **20 seconds** press for **three times** consecutively one button of each remote control to be activated or to keep working, waiting each time the LED relighting and the BEEP from the buzzer. Confirmation:
 - **2 Beeps** close together and **2 blinks** of the LED confirm that the remote control has been saved.
 - **4 Beeps** close together and **4 blinks** of the LED indicate that this remote control has already been enabled.
 - **6 Beeps** close together and **6 blinks** of the LED indicate that the 4 remote controls foreseen are already enabled. No others can be added.
- 3) Once activated the last one, turn **ON / OFF** the ignition key one time or wait for 30 seconds.

WARNING:

- With the **TX PAR LW** you can use any one of the **4** keys available and press different keys of the same remote control for the **3 times** requested.
- The remote controls that are not used in this operation are disabled; **they can be re-enabled by repeating the operation.**
- Once activated the procedure, it is possible to learn the electronic keys.

PAIRING / CUTTING OUT OF THE CHD 400 ELECTRONIC KEYS:

- 1) With the system in off position, enter the EMERGENCY CODE as shown on the PIN CARD.
- 2) TWhen the confirmation BEEPS end and the LED is switched on fixed again, within **20 seconds** press on the key socket for **3 close times** the metallic part of each **key CHD 400 to be activated or to keep working, waiting each time the LED relighting and the BEEP from the buzzer.** Each time pressed, the system reacts with the following indications:
 - **1 Beep** and **LED switching back ON**, means that the procedure is progressing correctly, which is confirmed after the key is pressed for the third time by **3 BEEPS** close together and **3 blinks** of the LED.
 - **2 Beeps** close together and **2 short blinks** of the LED mean that the 2 keys foreseen have already been enabled. No others can be added.

WARNING:

If the contact is not close enough, although the confirmation signal, it could be necessary to press the key again: **only 3 close BEEPS and 3 LED flashings** indicate the correct read in.

- 3) Once activated the last one, turn **ON / OFF** the ignition key one time.

WARNING:

- The unused keys during this operation **are deactivated; they can be activated again by repeating the procedure.**
- Once activated the procedure, it is possible to learn the remote controls.

EMERGENCY DESACTIVATION

The system can be deactivated without the remote control using the following procedure shown on the **PIN CARD** too, or using the emergency electronic key **CHD 400**.

USE OF THE EMERGENCY CODE

- 1 Remove the PIN CARD label: the EMERGENCY CODE is now shown.
- 2 Insert the ignition key and turn it one time [+15] ON/OFF to switch the LED ON (red pilot light).
- 3 Before the LED is switched OFF, press its button as many times as the first number of the code; each time the LED switches OFF and 1 Beep to confirm.
- 4 Wait until the LED is OFF and ON again.
- 5 Repeat the 3-4 steps for each remaining code numbers.

The usual desactivation signal confirms the operation has been completed successfully.

PRESS THE BUTTON ONLY WHEN THE LED IS ON

ALARM FUNCTIONS

When the system is activated the alarm is given / signalled by the siren, the direction indicators, the LED and the additional warning horns.

Cycles of about 25 seconds, with cut off by the remote control or the emergency procedure

OPENING OF DOORS, HATCH DOORS, BONNET OR BOOT:

Connected to the LIGHT BLUE/WHITE wire, which can be configured in two different ways:

- **Instantaneous** on the system activation.
- **Delayed** by **30** or **50** seconds on activation, then instantaneous.
- The alarm is not repeated if the door is left open.
- 3 alarm cycles if the door is left open, 1 if it is opened and closed again.
You can set just 1 alarm cycle instead of the 3 standard cycles, with the door open.
- The alarm is repeated only if the door is closed and opened again after the current cycle is terminated.
- Unlimited alarm cycles.

OPENING OF DOORS, HATCH DOORS, WINDOWS AND STORAGE COMPARTMENTS

Detected via radio by the wireless sensors of series: MIC LW, MIC MEC LW:

- **Instantaneously** when the system is activated: opening the door, the windows, storage compartment, etc.
- If, when the system is activated, the door, bonnet, windows, storage compartment, etc. is / are already open, the sensor does not send the alarm.
To activate the alarm it / they must be closed and opened again.
- The alarm cycle is not repeated if the door, the windows, storage compartment, etc. is / are left open.
- The alarm is repeated only if the door is closed and opened again after the current cycle is terminated.
- For the whole time the system is activated, 10 overall alarm cycles at the most are possible from the wireless sensors of the series: MIC LW, MIC MEC LW.

INTRUSION FROM INFRARED SENSOR

Detected by the wireless sensors of the series: **SEN INFRA LW, SEN INFRA 360 LW:**

- There must be a lapse of 2 / 3 minutes between 2 subsequent detections, therefore if you get out of the vehicle and the system activates immediately, the sensor will only be operational at the end of the 2 / 3 minutes.
- The alarm is only repeated after the set 2 / 3 minutes if there is another intrusion or if the person in the vehicle makes other movements.
- For the whole time the system is activated, 10 overall alarm cycles at the most are possible among all the wireless sensors: SEN INFRA and MIC LW, MIC MEC LW choked.

IGNITION KEY (for at least 2 seconds):

- The starting attempt causes an alarm cycle.
- The alarm is not repeated if the key is in the **ON** position (instrument panel lit).
- The alarm is repeated only if the key is turned back in the **OFF** position and then left in the **ON** position for at least 2 seconds.
- Unlimited alarm cycles.

INTRUSION FROM ULTRASONIC RADAR SENSOR:

- The alarm cycle is repeated with a break of 5 seconds, if the alarm cause persists continuously.
- The blinding / masking of the sensors, if detected on the system activation, causes some warning signalings (LED, direction indicators, siren).
If it is detected with the system activated, it is able to generate 10 alarm cycles.
- As long as the system is activated a maximum of 10 alarm cycles is possible from the ULTRASONIC sensor.

WARNING:

- If an alarm occurs during another one, this last one will be not considered

ULTRASONIC SENSOR

The internal microprocessor monitors the vehicle continuously, constantly adapting its working parameters to the environment where it is installed to better understand and identify the real alarms from false signalings. Only activate if there is nobody and no animal in the vehicle; all the windows have to be closed; there must be no mobile objects or sunshades in order to avoid false alarms.

The **ANTI-TAMPERING** (anti-masking and anti-blinding) function constantly controls the efficiency of the sensors and of their wirings, warning in case of any attempts. On its activation it checks its correct working conditions and its own parameters in full, then it starts the vehicle surveillance (flashing LED). The anomalies, if any, are signalled by the siren and by the direction indicators flashing for some seconds, followed by 5 BEEPS subsequent to the deactivation of the system.

SELF - DIAGNOSIS

The system has the self-diagnosis, that is it constantly checks its good and correct working.

6 BEEPS and **6 short flashings** of the LED after the deactivation of the system indicate some anomalies in the system.

Contact your fitter as soon as possible.

REDUCTION OF THE CURRENT CONSUMPTION

To reduce at the maximum the current consumptions and protect the vehicle's battery life, the central unit cuts the ultrasonic sensor out and the warning LED after 8 "on duty" days without any alarms.

The ultrasonic sensor activates itself again on any alarm detection from the buttons or from the ignition key.

LOW BATTERY

If the vehicle's battery slowly gets down (due to some lamps or other devices left on), the siren deactivates itself without causing any alarms, with the central locking always blocked and the immobilizer remaining active.

Charge the vehicle battery again following the specific instructions, then deactivate the system by the remote control, the electronic key or the emergency code.

Feeding the system, short confirmation signal from the buzzer of the siren.

PROGRAMMING

The system can be customised or wireless sensors can be added through programming.

To enter into the PROGRAMMING mode:

1 With doors, bonnet and boot closed, turn the ignition key **[+15] ON** and **OFF** once to switch the LED ON.

2 During the **2 seconds** in which the LED is lit, start to briefly press the LED button to:

- **11 times** consecutively (**program USER / VEHICLE functions**).

Confirmation:

short, low tone BEEP of the buzzer, followed by a very long BEEP and by some LED flashings. When the LED is fixed, we are in the programming phase.

- **12 times** (**pair / test / delete wireless sensors**).

Confirmation:

short two tone BEEP of the buzzer, followed by some BEEPS combined with some LED flashings. When the LED is fixed, we are in the programming phase.

Every time the led switches OFF for confirmation and the buzzer of the siren gives 1 BEEP.

WARNING:

Pressing the LED button the BEEP of the buzzer confirms the signal has been recognized by the central unit.

- If the LED switches off autonomously within 2 or 3 seconds, wait for 30 seconds and repeat the procedure again from point 1.

3 With the LED lit fixed press its button as many times as the chosen programming (consult the relevant tables on the pages that follow).

- On every valid pulse the LED switches off temporarily and the buzzer gives 1 BEEP.

4 Once terminated the sequence, after some seconds the system signals the programming has been accepted giving a two tone signal, a series of BEEPS or a musical sequence and the LED is now lit fixed again.

- Short BEEPS and very quick flashings of the LED indicate a denial: the made programming does not exist.

5 End the procedure, switch the ignition key **[+15] ON** and **OFF** once.

WARNING:

- The procedure can be started only if the system is deactivated.
- Once entered into the programming mode it is possible to set up in succession more functions belonging to the same category.
- The completed and confirmed programmings remain active also when the central unit is not fed.
- The installer can select the vehicle "to be loaded" into the central unit to interface the original system (line) and make all the **program USER / VEHICLE functions** programmings by means of the special SK KIT and a Personal Computer (office or laptop), using the specific MED SOFTWARE, **4.5** or following versions.

USER'S PROGRAMS (11 TIMES)

DIRECTION INDICATORS'S FLASHING ACTIVATION / DESACTIVATION
3 Cutting out / Activation - standard setting
ACOUSTIC SIGNALINGS ACTIVATION / DESACTIVATION
4 Cutting out / Activation - standard setting
5 Out of order / On duty - standard setting

INSTALLER SECTION PAIRING WITH THE VEHICLE



AND WITH THE INSTALLED ACCESSORIES



**WARNING: Every change in these parameters can
Compromise the correct working of the system.**

BUTTON INPUT CUTOFF / ACTIVATION (Light Blue/White wire)
6 Cutting out / Activation - standard setting
SETTING OF THE DOORS LOCKING/UNLOCKING TIME
7 1,25 seconds locking / unlocking - standard setting
8 3 seconds locking / unlocking
9 10 seconds at locking - 1,25 seconds at unlocking
10 30 seconds at locking - 1,25 seconds at unlocking
FIXED / TIMED STATUS SIGNAL
11 Timed (10 sec. Standard) / Fixed - standard setting
TIME OF THE STATUS SIGNAL IF TIMED
12 10 seconds - standard setting
13 30 seconds
14 45 seconds
DELAYED TIME ON ACTIVATION BUTTONS (Light Blue/White wire)
15 Simultaneous (0 second) - standard setting
16 30 seconds
17 50 seconds
ALARM OUTPUT
18 Fixed / Intermittent - standard setting
ANTI-TAMPERING OF THE ULTRASONIC SENSOR
19 Cutting out / Activation - standard setting
ULTRASONIC SENSOR
20 Cutting out / Activation - standard setting
ULTRASONIC SENSOR SENSITIVITY
22 Low
23 Medium - standard setting
24 High
DIRECTION INDICATORS CONTROL
25 With 2 wires by relays separated channels (right/left side separated) - "USUAL CONNECTION"
26 Single negative control with starting and final blinking IMPULSE - standard setting
27 Single negative CONTINUOUS control
ALARM CYCLES NUMBER FROM BUTTONS INPUTS
28 3 alarm cycles / 1 alarm cycle - standard setting
RESET OF THE INITIAL CONDITIONS PROGRAMMED AT DEFAULT
35 Standard values setting

The central unit works even without the a.m. Programmings.

DIRECTION INDICATORS FLASHING ON THE SYSTEM ACTIVATION / DESACTIVATION

To activate signalling also when activating / deactivating, besides in the alarm state.

ACOUSTIC SIGNALINGS ON ACTIVATION / DESACTIVATION

The exclusion function just keeps the service indications enabled: alarm memory, input of emergency code, input refusal, and programming.

OUT OF ORDER OF THE SYSTEM

Suggested in case the vehicle has to stay in the repair shop, garage, or when the vehicle does not need to be protected. See PROGRAMMINGS. When OUT OF ORDER, the system cannot be activated and any attempt gives 5 BEEPS and 5 LED flashings. It cuts out all the central unit functions. It excludes all the functions of the control unit, including the PANIC function.

Repeat the programming to activate the system completely again.

BUTTONS INPUT DESACTIVATING

It is used to disable the detection function of the door, bonnet and boot buttons, leaving the other protection systems activated: starting, volumetric radar sensor, wireless sensors.

It may also disable supplementary modules, if connected to the Light Blue/White wire.

WARNING:

To use only in case one button or one additional sensor is broken waiting for their repair.

DOORS LOCKING / UNLOCKING TIME

STATUS OUTPUT - TIMED STATUS SIGNAL

The standard preset times are **1,25 secondi**.

With vehicles having a "comfort" equipment (simultaneous windows closing by turning the original key in the door lock block), it is possible "to automate" the windows closing on the system activation delaying the doors locking time or using the status output as timed, according to the vehicle's features.

If necessary, it is possible to let the controls of the doors locking and of the windows closing be simultaneous, and to preset the opening / closing times at 3 seconds (for example, vehicles equipped with pneumatic system like MERCEDES W 124 - W 129 series).

With vehicles equipped with security lock activated by the double control on the doors locking wire, this function can generally be activated only with med software.

STAND-BY TIME OF THE INSTANTANEOUS / DELAYED BUTTONS INPUT

When the system is activated, the analogue input of the Light Blue/White wire may be instantaneous or delayed by 30 or 50 seconds (for the initial seconds and then it becomes instantaneous). It must be delayed when the signal is taken by the delayed switching off internal roof lamp or if are used the additional modules (anti lifting, high frequency, infra red etc).

The set up depends on the vehicle model and on the paired accessories)

ALARM OUTPUT

It has to be kept intermittent only if it's used to control the vehicle klaxon otherwise fix in case of an additional siren.

NUMBER OF ALARM CYCLES FROM THE BUTTONS INPUTS

It is used to execute 3 alarm cycles from the analogue buttons line (rather than just 1), if the alarm condition persists (for example: opening and leaving a door open; if it is closed again before the end of the 3 cycles, the alarm stops at the end of the current cycle).

The alarm cycles are repeated if the door is subsequently opened again.

RESETTING OF THE INITIAL CONDITIONS PROGRAMMED AT DEFAULT

It allows to restore the original condition of the central unit, resetting all the default programmings.

WIRELESS SENSORS PROGRAMS (12 TIMES)

<p style="text-align: center;">PAIRING WIRELESS SENSORS OF SERIES MIC LW, MIC MEC LW, SEN INFRA LW</p> <p>5 It adds new sensors.</p>
<p style="text-align: center;">FORCED PAIRING OF CHOKED WIRELESS SENSORS</p> <p>7 It adds new sensors of series MIC LW, MIC MEC LW as choked sensors</p>
<p style="text-align: center;">TESTING WIRELESS SENSORS</p> <p>12 It activates the operational test for all the sensors of series: MIC LW, MIC MEC LW, SEN INFRA LW</p>
<p style="text-align: center;">ELIMINATING WIRELESS SENSORS</p> <p>20 It deletes all the paired sensors of series: MIC LW, MIC MEC LW, SEN INFRA LW</p>

The wireless sensors supplied in the pack are already paired with their control unit.

PAIRING WIRELESS SENSORS OF SERIES MIC LW, MIC MEC LW, SEN INFRA LW

The procedure is used to manage the sensors of series MIC LW and MIC MEC LW, which are always enabled when the system is activated, up to a maximum number of **30**, and the infrared sensors SEN INFRA LW.

You are recommended to carry out the procedure on a workbench, or in any event near the alarm control unit before fitting the sensors on the vehicle, making sure to install the power supply batteries in them beforehand.

The **LED / BUTTON** and the siren **SIR 050** must be connected when the control unit is powered.

 **The battery-holder supports can only be fitted in the MIC LW and MIC MEC LW if they are already complete with the battery CR 2032, otherwise it will be impossible to take them out again.**

1) Once in programming mode (button of the LED pressed **12 + 5 times**) according to the procedure just described, which is confirmed by the signals indicated, the LED is now lit steady. You can now add new sensors in addition to those supplied in the pack (which do not have to be paired again), as follows:

2) **MIC LW** = Rest the magnet for **2 seconds** and move it away from the arrow over the MED mark, until confirmation is given **3 times** consecutively.

MIC MEC LW = Press the built-in button of the sensor for **2 seconds** and release it, until confirmation is given **3 times** consecutively.

SEN INFRA LW / SEN INFRA 360 LW - The infrared sensors are supplied in TEST mode, therefore after pairing them and testing them on the vehicle, they have to be set in standard service mode, following the instructions below.



Pass in front of the sensor until its LED switches on and the control unit provides confirmation **3 times** consecutively, or simply open and close the casing, again **3 times** consecutively (the anti-sabotage button trips).

Control unit confirmation:

- **2** Beeps close together and **2** blinks of the LED confirm that the sensor has been stored.
- **4** Beeps close together and **4** blinks of the LED indicate that this sensor has already been enabled.
- **6** Beeps close together and **6** blinks of the LED when all **30** sensors envisaged have already been enabled.

To add others, delete those already paired via the specific program and teach-in just those really in use again.

3) End the procedure, switch the ignition key **[+15] ON** and **OFF** once.

WARNING:

- Perform the teach-in procedure slowly and always make sure the confirmation signals are given:
 - **1 Beep**, LED **OFF** and **ON** after each transmission;
 - **2, 4 or 6 Beeps** and **blinks** of the LED after the **3** sequential transmissions for each sensor.

Without the final indication (2, 4 and 6 BEEPS), after 5 seconds, repeat the saving procedure again.

- Once in programming mode, or between the pairing procedures of 2 different sensors, no more than **2 minutes** must lapse, otherwise exit and access the procedure again to complete the pairing procedure.
- The paired sensors remain stored even if the control unit is not powered until they are deleted via the specific program.
- The infrared sensors are recognised by the system and are always managed as choked sensors.

FORCED PAIRING OF WIRELESS SENSORS AS CHOKED

The procedure is used to manage a part of the sensors of series MIC LW and MIC MEC LW as choked, or rather that can be excluded together with the radar and infrared sensors, up to a maximum of 10, including infrared sensors of series SEN INFRA LW.

Following the instructions, the procedures and the warnings given for the teach-in function of the wireless sensors explained earlier, with the only difference being that of accessing the programming function by pressing the button of LED **12 + 7** times to force them as "choked".

WARNING:

- If the same sensor MIC LW or MIC MEC LW is enabled as both standard and choked, the control unit will consider it to be "**choked**".
- When a sensor MIC LW or MIC MEC LW is saved as choked, if you want to reset it as a standard sensor, you have to delete all of them and teach them in again.

TESTING WIRELESS SENSORS

The procedure is used to quickly test the correct transmission of the wireless sensors, to check which group they belong to and which of them sent the last alarm signal.

- 1) Program by pressing the button of the LED **12 + 12** times.
- 2) After the confirmation signal is given, while the LED is lit steady, activate all the sensors to be tested individually; for each activation, the buzzer and the LED will provide the following indications:
 - 1** Beep and **1** blink = standard wireless sensor;
 - 2** Beeps and **2** blinks close together = choked wireless sensor;
 - 5** Beeps and **5** blinks close together = wireless sensor that sent the last alarm.
- 3) Turn the ignition key **[+15] ON** and **OFF** once to end the TEST.

WARNING:

- The test can be carried out as many times as you like.
- During the test phase, you can interrogate the same sensor a number of times; the indication does not change.
- If you exit test mode or the power supply is disconnected from the control unit, the indication of the last wireless sensor that sent the alarm is deleted.
- The indication of the last wireless sensor that generated the alarm is not affected by other alarm causes: ignition key, radar sensor, buttons of doors detected by the light blue/white wire or by the CAN line, therefore the last alarm encountered may not depend on these sensors.

When an alarm triggers, after de-activating the system, always check the alarm memory.
- During the test phase, if nothing is done for 3 / 4 minutes, the test exits automatically.

Turn the ignition key **[+15] ON** and **OFF** once all the same.

DELETING WIRELESS SENSORS

The procedure is used to simultaneously delete all the paired wireless sensors of series:

MIC LW, MIC MEC LW, SEN INFRA LW, SEN INFRA 360 LW.

- 1) Program by pressing the button of the LED **12 + 20** times.
- 2) After the confirmation signal is given, when the LED is lit steady, turn the ignition key **[+15] ON** and **OFF** once. All the wireless sensors are now deleted.

WARNING: Repeat the pairing procedure for ALL the sensors in use.

MAINTENANCE

The central unit does not need any maintenance.

The sensors MIC LW, MIC MEC LW and infrared sensors have to be installed inside the vehicle, protected against the infiltration of liquids and condensate and away from heat sources.

The lens of the infrared sensors must not be knocked.

The sensors can be cleaned using a dry cloth. Do not use solvents or paint thinners.

The sensors MIC LW, MIC MEC LW, SEN INFRA LW, SEN INFRA 360 LW and the TX PAR LW have an indicator LED to check the efficiency of the internal battery.

When the battery runs low, it can be replaced with the following types of batteries:

- MIC LW, MIC MEC LW and TX PAR LW **3V lithium** batteries, type **CR 2032**
- SEN INFRA LW and SEN INFRA 360 LW **3V lithium** batteries, type **CR 123 A**



When replacing the battery, do not touch the circuit or the battery with wet hands.

Do not attempt to charge dead batteries. Do not throw on the fire. Do not swallow.

Dead batteries are to be disposed of in dedicated waste battery containers according to laws currently in force in the individual countries.

Strictly keep the sensors and the batteries out of children's reach.

WARNING:

- The **BATTERY HOLDER** can only be fitted in the MIC LW and in MIC MEC LW with the battery CR 2032 actually inserted, otherwise it will be impossible to take it out again.
- When washing the engine, protect the electronic siren adequately.

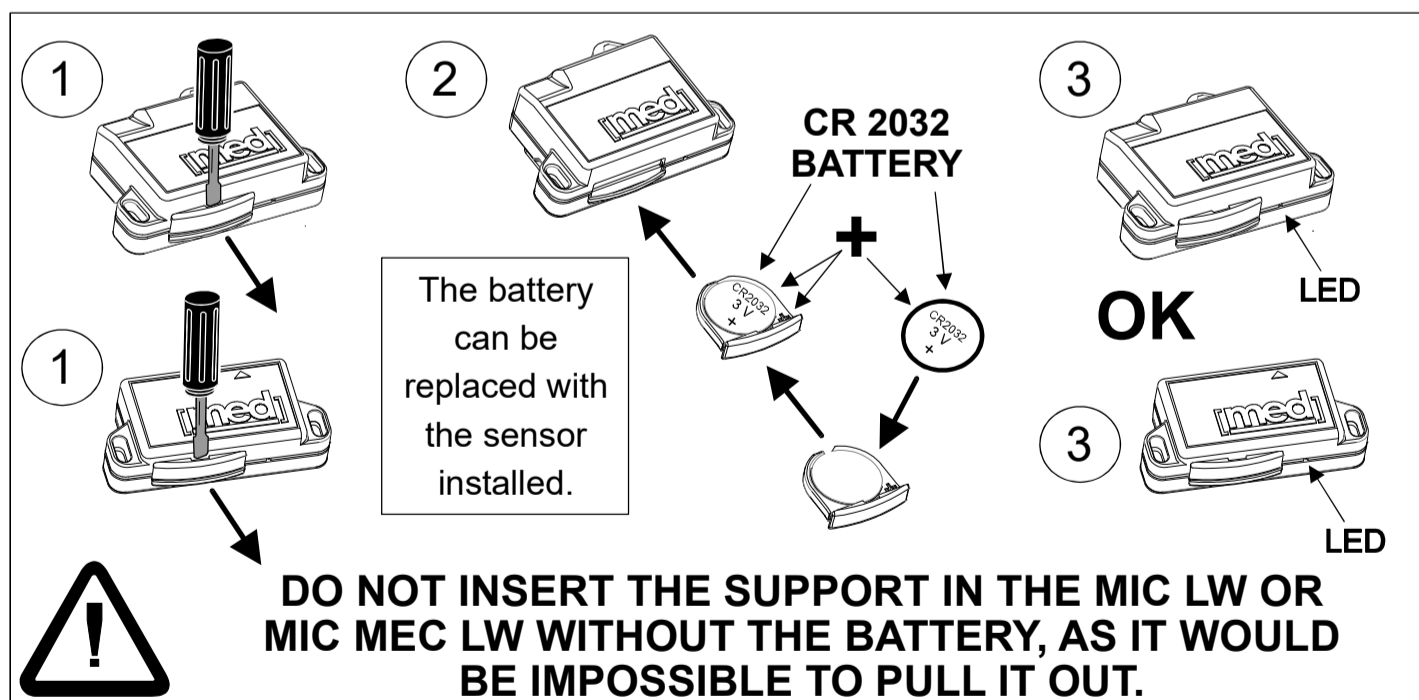
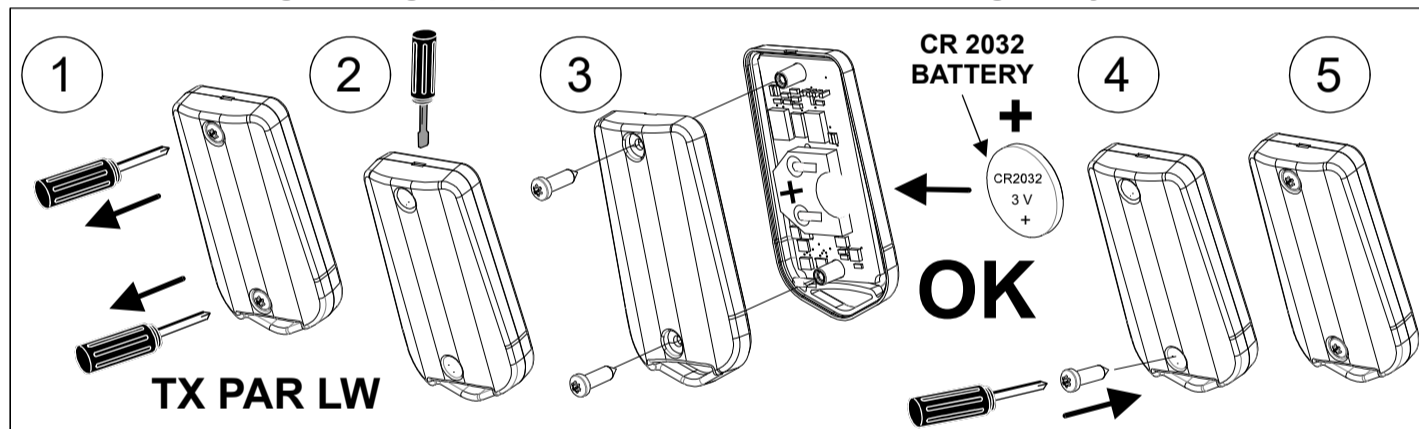

SEN INFRA LW

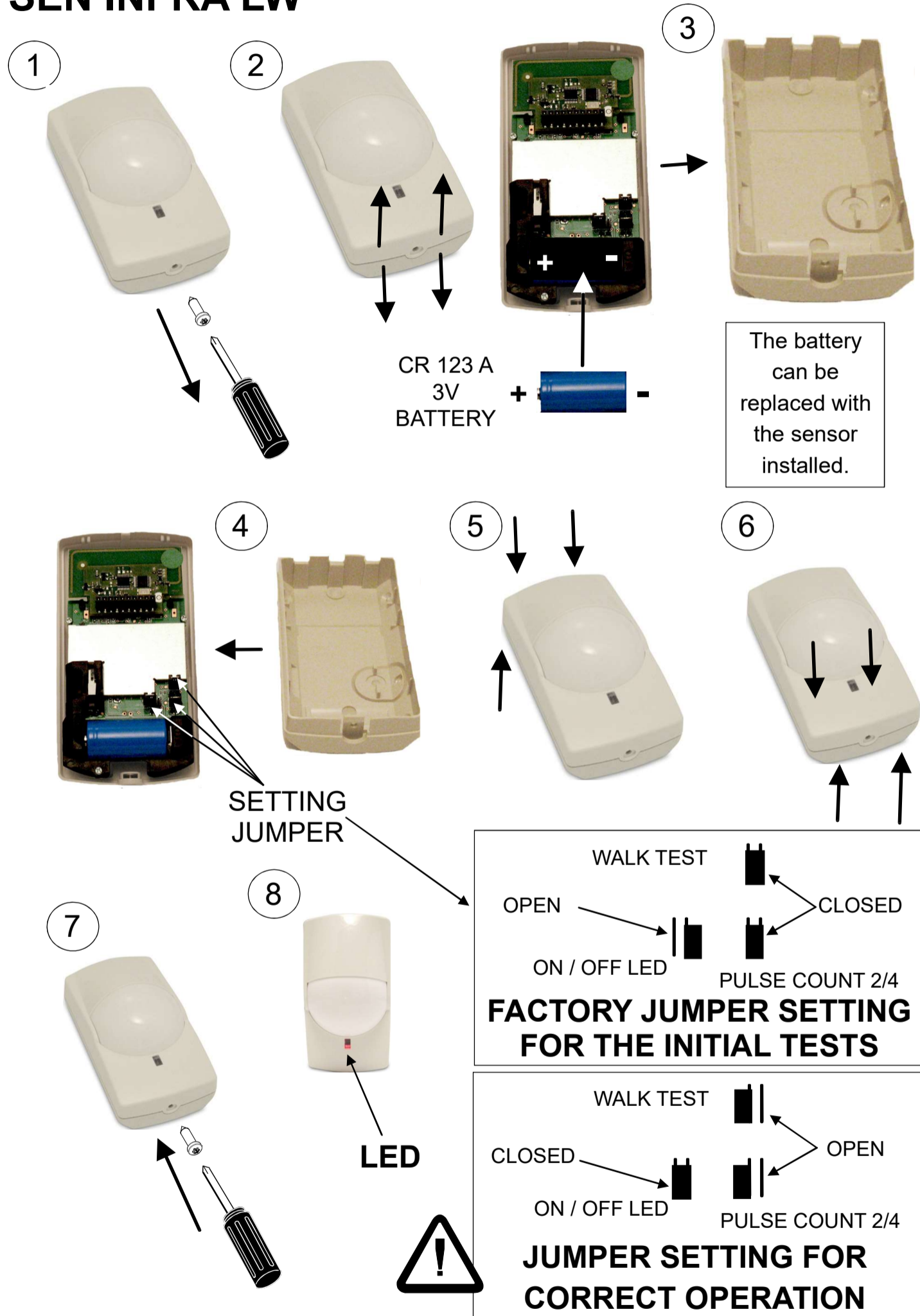

SEN INFRA 360 LW

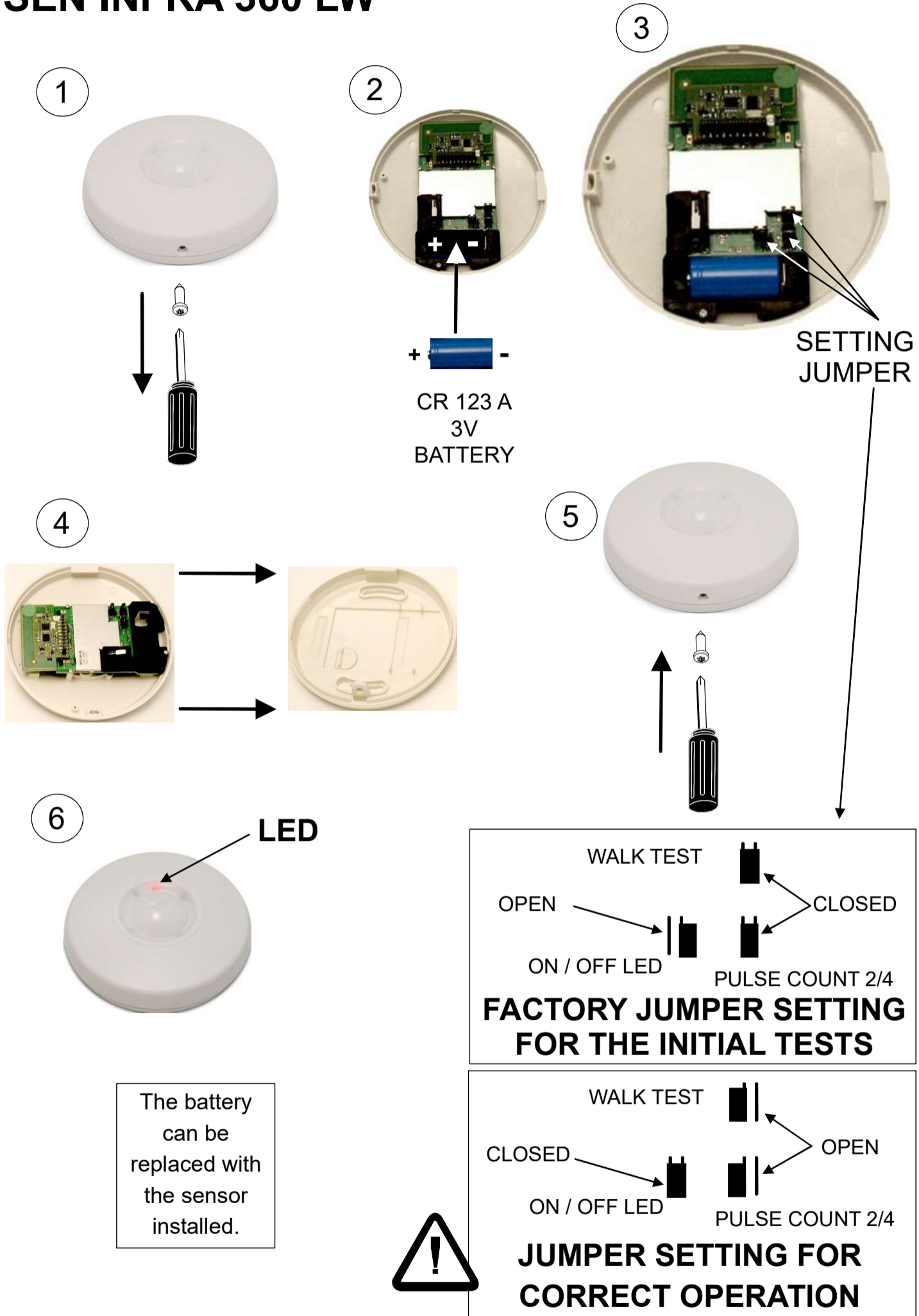

WARRANTY CONDITIONS

The technical warranty has a duration of 24 months from the date of installation, ex-works, and covers those parts considered as defective only by A.E.B. S.p.A. Any other external labor or extra costs are excluded.

HOMOLOGATIONS

The **MED 6000.LW** central unit is type-approved as an ALARM system according to Regulation **ECE / ONU** no. **R97** with the number: n. **(E24) 97R A -010061**

The **ECE / ONU Regulation** no. **97**, referring to functioning and safety of alarm systems is equivalent to the European Directive 95/56/EC and is also recognised in non EEC countries such as, for example, Russia, Japan, etc.

This regulation includes immunity to interference tests and the EMC tests in accordance with the **ECE / ONU Regulation** no. **10**.

Type approval also includes the electronic siren **SIR 050**, the wireless sensors of series **MIC LW, MIC MEC LW, SEN INFRA LW** and **SEN INFRA 360 LW**.

The sirens **SIR 050 - SIR 050.NA** are homologated in compliance with the **European Directive 2006/28/EC** concerning the electromagnetic compatibility (interferences and noises) under the following approval n. **e24 03 1793**

WARNING:

The **MED 6000.LW** central unit is been designed and developed according to the technical specifications detailed in the product's Technical File and listed in the Declaration of Conformity and Operating Instructions.

Tampering with this product, altering the aforementioned characteristics or intervening on the operation and connection in any way that differs from the installation instructions in the manual could invalidate the type-approvals obtained with the consequent refusal of any liability by A.E.B. S.p.A.

DECLARATION OF CONFORMITY

CE

Standard of reference ISO/IEC Guide 22 and EN 45014

Number of conformity: 001-2012/E

Name of the manufacturer: **A.E.B. S.p.A, antitheft division**
 Address: via dell'Industria, 20
 Corte Tegge
 42025 Cavriago (RE) Italy

HEREBY STATES THAT THE ELECTRONIC UNIT

Product: Camper alarm system 7000.LW

Control unit	Transmitter	Siren	Magnetic/mechanic sensor	Infrared volumetric sensor
MED 7000.LW	TX PAR LW	SIR 070	MIC LW / MIC MEC LW	SEN INFRA
MED 6000.LW				
MED 7000.BLW				
MED 6000.BLW				

WAS TESTED IN ACCORDANCE WITH THE FOLLOWING PRODUCT STANDARDS OR OTHER PRODUCT SPECIFICATIONS IN ORDER TO BE IN COMPLIANCE TO THE ESSENTIAL REQUIREMENTS OF THE DIRECTIVE 1999/5/CE (R&TTE):

Requirements	Standards applied
Human exposure to electromagnetic fields (art. 3.1a):	EN 62479:2010
Safety (art. 3.1a):	Relevant test mentioned in the ECE R97 Regulation Rev.1
EMC (art. 3.1b):	ECE R10 Regulation Rev.3
Radio spectrum (art. 3.2)	EN 300-220 (02-2010)

THE PRODUCT IS MARKED WITH CE MARK AND NOTIFIED NUMBER ACCORDING TO THE DIRECTIVE 1999/5/CE

CE 0678

Place of issue: Cavriago (RE) Italy Date of issue: 19/01/2012

CEO of A.E.B. S.p.A.
 Fiacadori Antonia

TECHNICAL FEATURES:

MED 6000.LW central unit

Feeding voltage:	12 Vdc (nominal) 8 / 16 Vdc
Current absorption: (average values)	< 10 mA (at rest) < 20 mA (activated system, first 8 days) < 12 mA (following days)
Temperature range:	from -40 °C to +85 °C
Place:	cockpit
Protection:	IP 40 (IEC 529 1989) - DIN 40050 - EN 60529
Direction indicators output with relay on 2 wires:	10 A + 10 A
Direction indicators output on a single wire:	NEGATIVE impulse - 0,7 A
Relay for central door locking:	10 A continuously - 15 A for 30 seconds
Relay for electrical cut off:	10 A continuously - 30 A for 30 seconds
Timed / fixed status output:	0.7 A
Additional alarm output:	0.7 A
Dimensions:	98 x 71 x 30 mm

TX PAR LW REMOTE CONTROL

Lithium batterie life:	about 2 years
Lithium battery:	n. 1 - CR 2032 - 3Vcc (nominal)
Temperature range:	from -20 °C to +85 °C
Protection:	IP 54 (IEC 529 1989) - DIN 40050 - EN 60529
Rolling-Code combinations	more than 18 billions of billions
Dimensions:	70 x 39 x 14 mm

CHD 400 KEYS

Life:	unlimited
Temperature range:	from -40 °C to +85 °C
Protection:	IP 40 (IEC 529 1989) - DIN 40050 - EN 60529
Rolling-Code combinations:	more than 18 billions of billions

SIR 050 - SIR 050.NA SIREN

Feeding voltage:	12 Vdc (nominal)
Current absorption:	1 mA (at rest) 1 mA (activated system) - (average values)
Temperature range:	from -40 °C to +85 °C
Protection:	IP 67 (IEC 529 1989) - DIN 40050 - EN 60529

MIC LW - MIC MEC LW

Lithium batterie life:	about 1 year
Lithium battery:	n. 1 - CR 2032 - 3Vcc (nominal)
Temperature range:	from -20 °C to +85 °C
Protection:	IP 40 (IEC 529 1989) - DIN 40050 - EN 60529
Rolling-Code combinations:	more than 18 billions of billions
MIC LW - Dimensions:	60 x 30 x 16 mm
MIC MEC LW - Dimensions:	60 x 44 x 18 mm

SEN INFRA LW - SEN INFRA 360 LW

Lithium batterie life:	about 1 year
Lithium battery:	n. 1 - CR 123A - 3Vcc (nominal) - 1300 mA h
Temperature range:	from -20 °C to +50 °C
Protection:	IP 40 (IEC 529 1989) - DIN 40050 - EN 60529
Rolling-Code combinations:	more than 18 billions of billions
SEN INFRA LW - Dimensions:	115 x 62 x 50 mm
SEN INFRA 360 LW - Dimensions:	120 x 120 x 40 mm

COMPANY
WITH QUALITY SYSTEM
CERTIFIED BY
BUREAU VERITAS
ISO 9001:2008

A.E.B. S.p.A. a socio unico / a single member Company - Via dell'Industria, 20
42025 - Corte Tegge - Cavriago (RE) - Italy
med è un marchio / is a trademark of A.E.B. S.p.A. www.medautomotive.it
e-mail: service@medautomotive.it



CERTIFICATO DI INSTALLAZIONE - INSTALLATION CERTIFICATE

Il sottoscritto, Thundersigned: _____

Installatore CERTIFICA di aver eseguito PERSONALMENTE il montaggio del DISPOSITIVO descritto qui di seguito, conformemente alle istruzioni del fabbricante.

Installed CERTIFIES that the fitting of the DEVICE described below was carried out by him PERSONALLY, in accordance with the instructions of the manufacturer.

Descrizione del VEICOLO - Description of the VEHICLE:

MARCA, TRADEMARK: _____ MODELLO, TYPE: _____

NUMERO di SERIE, SERIAL NUMBER: _____

NUMERO di IMMATRICOLAZIONE, REGISTRAZION NUMBER: _____

Descrizione dell'ALLARME secondo la Norma ECE 97 R (Equivalente alla Direttiva Europea 95/56/CE): Description of the ALARM as for European Standards 97 R (Equivalent to European Directive 95/56/EC):		
Modello, Type Matricola, Registration	MED 6000.LW	SIR 050 / SIR 050.NA
SENSORE RADAR, RADAR SENSOR	Yes - Sì <input type="checkbox"/> No - No <input type="checkbox"/>	ALTRO / OTHER

Applicare nei riquadri le etichette adesive fornite in confezione con i dati indicati e completare il modulo.
Apply the supplied labels with the relevant data and complete the form.

Installato a, Installed at: _____ Il, On: _____

Indirizzo completo dell'installatore,
Full address of installer:

TIMBRO, STAMP

FIRMA DELL'INSTALLATORE, SIGNATURE: _____

AVVERTENZE GENERALI PER L'UTENTE: DA CONSERVARE A BORDO DEL VEICOLO

- L'INSTALLAZIONE deve essere eseguita da PERSONALE QUALIFICATO, secondo le istruzioni specifiche.
- L'INSTALLATORE DEVE rilasciare al PROPRIETARIO del veicolo il presente CERTIFICATO DI INSTALLAZIONE completamente compilato e firmato, **valido anche per la GARANZIA del prodotto**.
- L'INSTALLAZIONE di un DISPOSITIVO di ALLARME per veicoli secondo la Norma **97 R** comporta:
 1. Il collegamento di TUTTI i pulsanti di porte, cofano e baule, aggiungendo quelli mancanti.
 2. Il collegamento di un AVVISATORE ACUSTICO.
 3. Se è previsto il SENSORE RADAR, deve essere indicato nel presente modulo.

A.E.B. S.p.A. declina ogni responsabilità e sospende la GARANZIA in caso di utilizzo improprio del prodotto o di parte di esso, di manomissione o di abbinamento a dispositivi non previsti.

GENERAL WARNINGS FOR THE USER: PRESERVE INSIDE THE VEHICLE

- INSTALLATION must be conducted by QUALIFIED PERSONNEL and according to the instructions.
- The INSTALLED MUST provide the OWNER of the vehicle with the present INSTALLATION CERTIFICATE, completed in full and signed. **Valid also for the guarantee of the product.**
- INSTALLATION of an ALARM DEVICE for vehicles in accordance with the **European Standard 97 R** requires:
 1. The connection of ALL the door, hood, and boot buttons, adding those that are missing.
 2. The connection of an ACOUSTIC SIGNALER.
 3. If the alarm system includes a RADAR SENSOR this must be indicated in the present form.

A.E.B. S.p.A. Declines all responsibility and withdraws the GUARANTEE / WARRANTY in cases of: the improper use of the product or part there of, tampering with the product, its combination with devices for which it was not specifically designed.

SI PREGA DI SCRIVERE IN STAMPATELLO - PLEASE WRITE IN BLOCK LETTERS

Tutti i diritti riservati. © 2017 AEB S.p.A. a socio unico All rights reserved. © 2017 AEB S.p.A. a single member
Con riserva di modifiche e di indicazioni errate. Company. Subject to changes and incorrect information.