

TECHNICAL FEATURES

Power Supply	:	12 V D.C.
Power Consumption	:	4 mA (with engine turned off)
	:	7 mA (with engine turned on)
Operating Temperature	:	from - 40° C to + 125° C
Cable Length	:	3 mt.
Protection	:	IP 54 (IEC 529 1989) - DIN 40050 - EN 60529

MAINTENANCE

med 57.3 CMI immobilizer requires no maintenance.

GUARANTEE TERMS AND CONDITIONS

The technical guarantee is for one year from the date of installation with ex-works terms for those defective parts but subject to the incontestable decision of med.

Under this form of cover the guarantee does not include costs for labour and any other type of obligation. The **GUARANTEE is only applicable for equipment for which we have received the appropriate "INSTALLATION CARD" properly filled in.**

IMPORTANT:

med is NOT RESPONSIBLE and the GUARANTEE is void in the event of inappropriate use of the equipment or parts thereof, tampering with or connection to unsuitable equipment. The installation should be done by qualified personnel.



med s.p.a.
Via Raffaello, 33
42100 Reggio Emilia (Italy)



Cod. 573.316.258 - 03/98



573316258

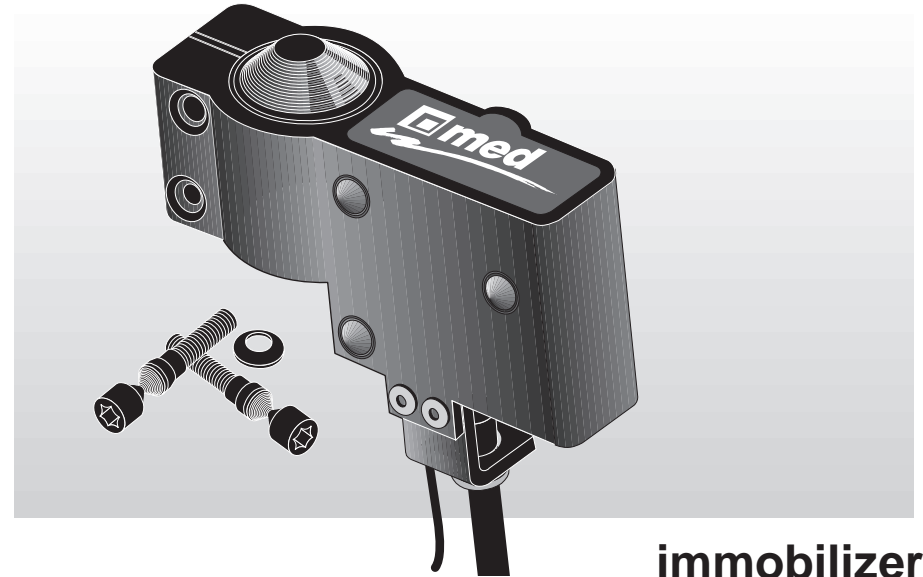

immobilizer

med 57.3 CMI

Electronic immobilizer for diesel vehicles with injection pump CAV - LUCAS type "DPC" or "DPS" with accessible ignition stop solenoid 12 V.

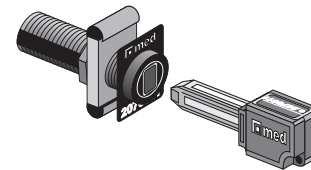

assembly instructions

Packing List:

- Immobilizer med 57.3 CMI
- Assembly instructions
- Bag with SAC 573 mounting accessories
- Bag with key holder and 2 keys
- Cables with Led

Legend

1.	Immobilizer med 57.3 CMI	13.	Contact protection cap
2.	Original nut	14.	M5 screw for strengthened cap
3.	Power supply cable of the advance electromagnetic device "enrichment" solenoid	15.	Heat shrinking sheath tube
4.	Original power supply wire [+15]	16.	Connecting cable with LED
5.	M5 hole	17.	Multipolar cable with LED
6.	M4 hole	18.	Red wire [+30] with fuse holder
7.	Solenoid contact tab	19.	med electronic key
8.	Multipolar cable med 57.3 CMI	20.	Key identification plate
9.	Unipole cable med 57.3 CMI	21.	med electronic key socket
10.	Washer under screw (springed)	22.	med four pole connector
11.	Fixing screw M4	23.	LED
12.	Strengthened cap	24.	Black wire (connection)

ASSEMBLY INSTRUCTIONS

- Make sure that the KEY PANEL is TURNED OFF (OFF position) and that the stopping solenoid for the injection pump is NOT BEING FED.
- Unscrew the original nut (2) that holds the power supply wire (4), from the threaded pin of the stopping solenoid (figure a).
CAUTION: Should the pump be fitted with the "enrichment" advance electromagnetic device, there will be two wires on the stopping solenoid. Remove them both (3 and 4) and connect them to cable (9).
- Remove the original power supply wire from the solenoid (4) and cut the terminal away.
- Insert in the best position the immobiliser (1) by tapping on it, on the stopping solenoid of the pump. Make sure that cable (8) and (9) come out of the lower part of the **med 57.3 CMI** without obstacles and that the space around enables the insertion and tightening of the 2 special breaking screws (11) and (14) respectively into holes 6 and 5 (figure b).
CAUTION: centre the head of the power supply tab (7) on the threaded pin of the solenoid, and make sure it remains in a horizontal position.
- Insert the threaded **M4** special breaking screw (11) in the hole (6). Interpose the spacer washer (10) (springed) maintaining its orientation and tighten by hand (figure c).
CAUTION: Do not break the screw and make sure that the tab (7) is in a horizontal position.
- Tighten the original nut (2) on to the threaded pin on the stopping solenoid of the pump to permanently lock the tab (7). If originally required insert the relevant washer (figure d).
- Protect the threaded pin of the solenoid with contact protection cap (13) by pressing as far as it can go. Now insert the strengthened cap (12).
- Insert the threaded **M5** strengthened cap screw (14) in the hole (5) and TIGHTEN by hand (figure e).
CAUTION: DO NOT BREAK THE SCREW!!
- Insert the heat shrinking sheath tube (15) on the original power supply wire (4) of the solenoid by peeling it and connecting it to the unipolar cable (9) (figure f).
CAUTION: If cable 3 is present, connect it together with cables 4 and 9 (figure f1).
- Solder the joints.

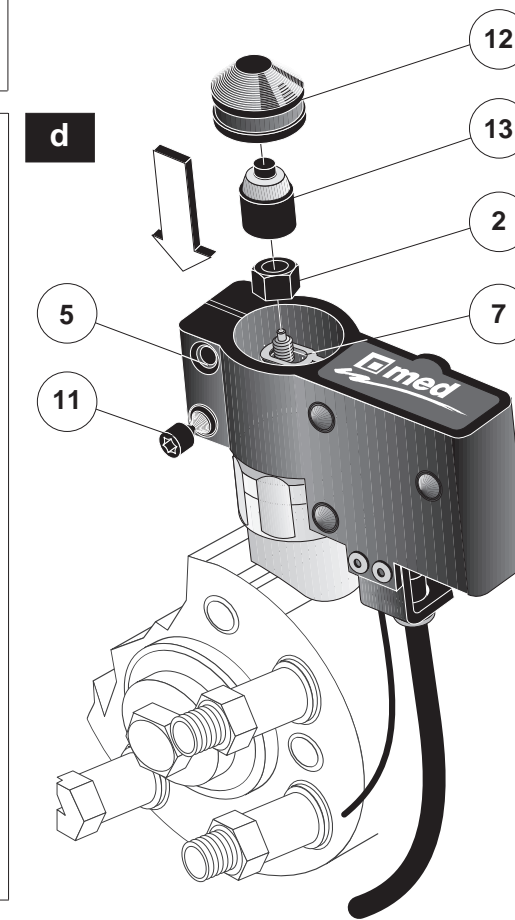
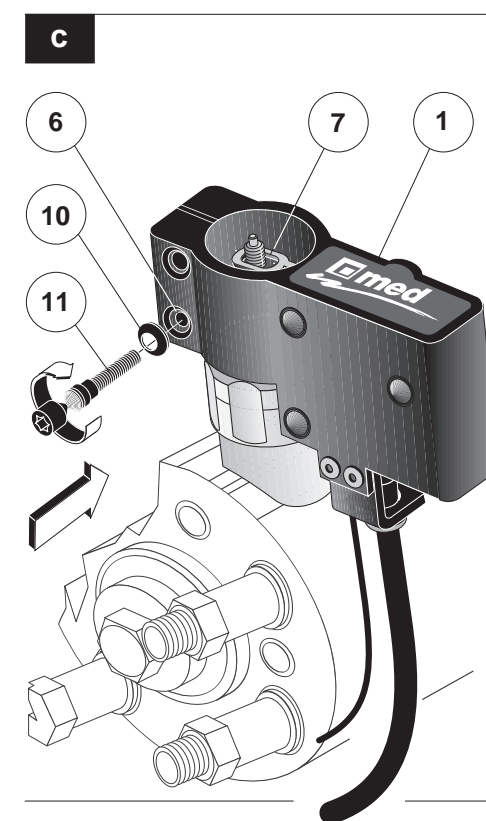
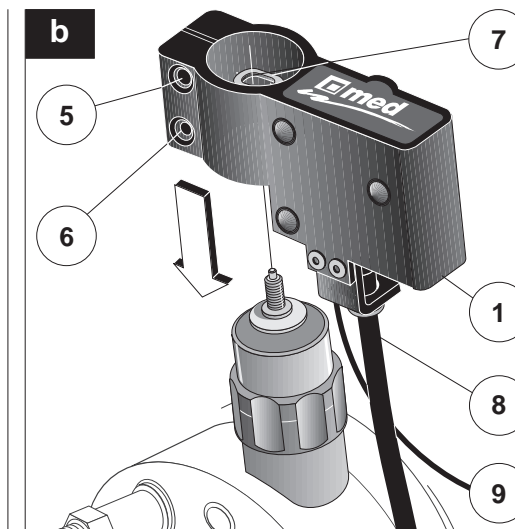
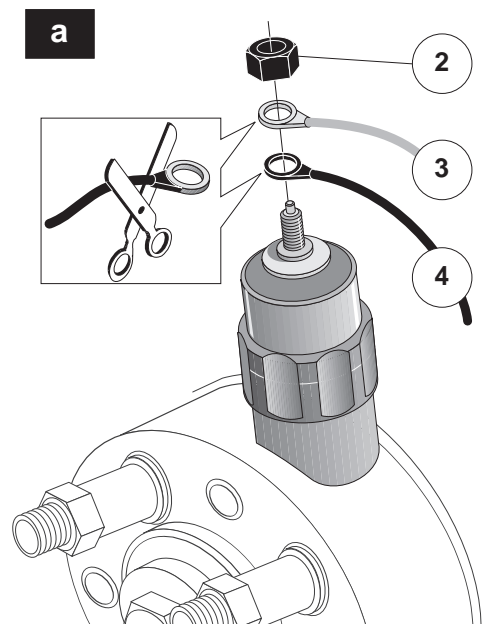

CAUTION: ALL CONNECTIONS SHOULD BE SOLDERED.

11. Place the heat shrinking sheath (15) over the joint, and heat seal it with an industrial type blower (or hair dryer.) Make sure the wires DO NOT get damaged.
 12. Fasten the joint with the heat shirking sheath (15) on to a ridged body (e.g. diesel tube for the injectors, support bracket, etc.) with an isolating clip.
 13. Extend and fix the multi-pole cable (8) of the med 57.3 CMI following the best path to connect the connector (16) of the multi-pole cable (17) and clip the connector. Avoid hot parts, passages which can damage the cable itself or the connector.
 14. Mount the LED display (23) (Ø 8 mm. hole) on the dashboard in a visible position (figure h).
 15. Mount the med key socket (21) (Ø 14 mm. hole) on the dashboard and fix the connector (22) to the rear. Leave the identification plate (20) well visible.
 16. Connect the RED wire (18) [+30] fitted with a fuse holder to a constant positive.
 17. Connect the black connection wire (24) to the negative terminal of the battery or on to another earthed point on the vehicle, as specifically provided by the manufacturer, where other wires are already connected.
 18. Carry out a test run as indicated in the section TEST RUN and WORKING ORDER.
 19. Only after a positive test run, screw down screws (11) and (14) to the BREAKING point obtaining the UNSCREWABILITY protection. Use a set screw wrench (figures g and i).
- # **CAUTION:** ALTERNATIVELY screw THE TWO SCREWS (11) and (14) giving each screw ONLY 1/4 of a turn each time, until the med 57.3 CMI is OPTIMALLY fitted.

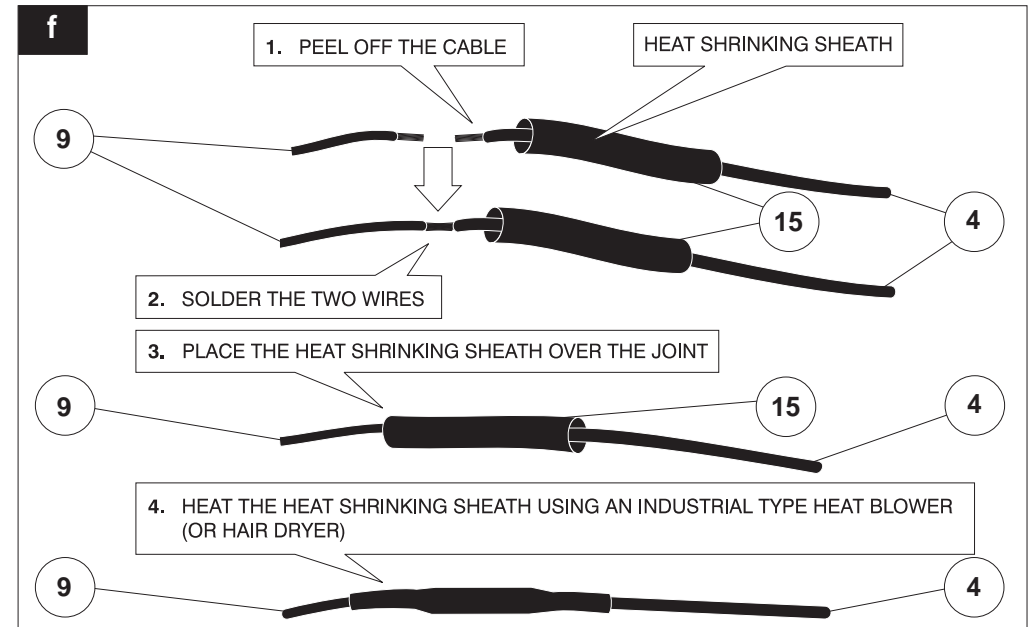
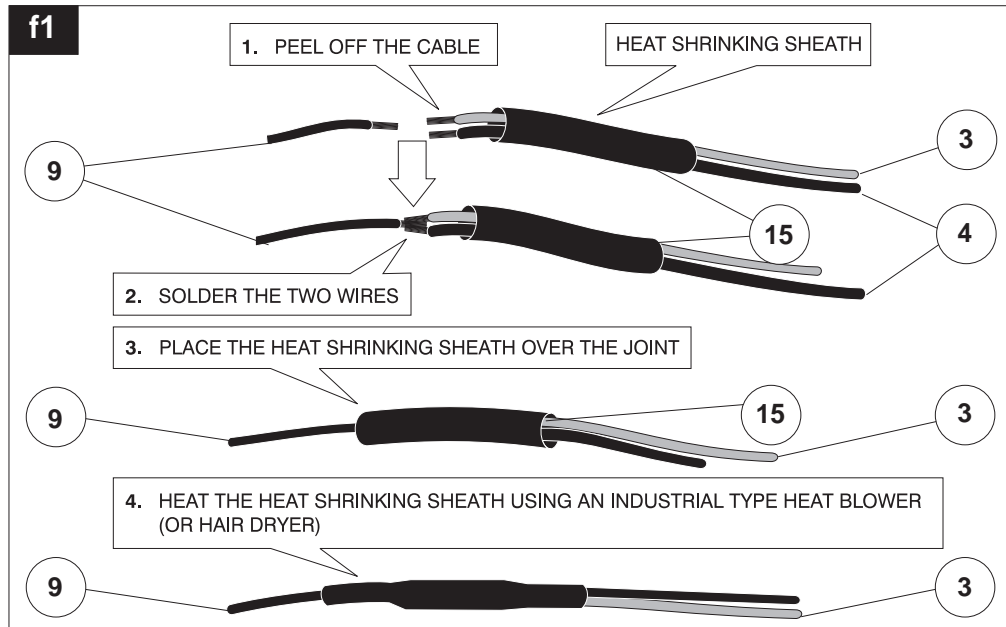
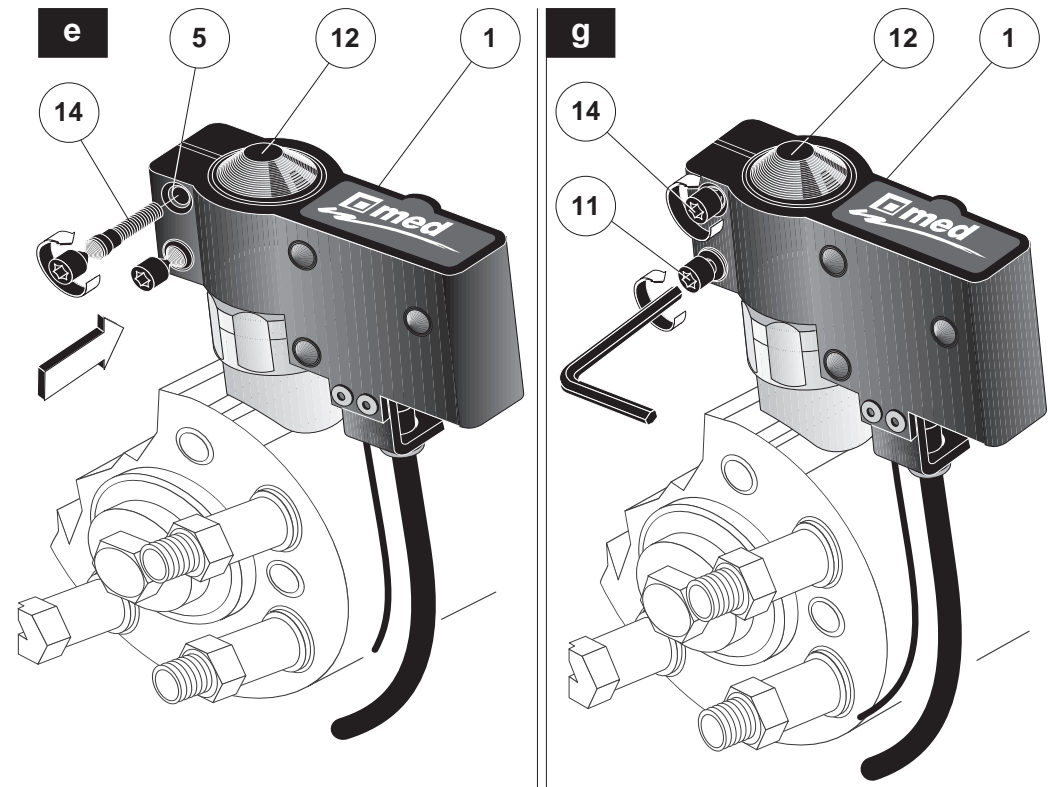

TEST RUN

1. Check that the engine DOES NOT start with the LED flickering.
2. Check that the engine starts with the LED constantly lit (the LED is turned off by turning the start key on to the ON position - panel turned ON.)
3. Confirm that the engine restarts within 20/30 SECONDS after it has been turned off.

WORKING ORDER

1. When the LED flickers it means that the **med** BLOCK-MOTOR is active.
2. When inserting the med electronic key in the socket, the LED lights up with a fixed light (code identified).
3. The engine can be started within 20/30 SECONDS after the **med** electronic key has been removed.
4. By turning the key panel ON (panel turned on) the LED is switched off and the engine can be started (anti-theft device deactivated).
5. After 20/30 seconds without having started the engine, the LED starts flickering and the BLOCK MOTOR is activated once again. To start the engine the above procedure has to be carried out again.

CAUTION:

With the engine turned off and the key left in the panel in OFF (panel turned OFF), after 20/30 seconds the LED starts flickering and the BLOCK-MOTOR is activated.

If the engine has to be turned off for a short time (e.g. at red traffic lights, level crossing, etc.) we advise that the panel key is turned to the OFF position (panel turned off - LED with fixed light) and immediately turn the key to the ON position, (panel turned on - LED turned off), without starting the engine. In this manner the engine may be started without having to use the med electronic key.

NB: It is NOT possible to start the engine with the med electronic key inserted.

