

TECHNICAL SPECIFICATIONS

Immobiliser med 64.0

Power voltage	: 24 V D.C.(rated)
Current absorption	: nil with system engaged (engine off) 0.32 A running
Temperature range	: between -40°C and +125°C
Insulation standard	: IP54 (IEC 529 1989) DIN 40050-EN 602529

med 600 UNIT

Power voltage	: 24 V D.C.(rated)
Current absorption	: 9 mA with system engaged (engine off) 20 mA with system disengaged

Temperature range	: between -40°C and +85°C
Max capacity internal relay contacts	: 30 A for 10 seconds
Continuous capacity internal relay contacts	: 20 A
Insulation standard	: IP40 (IEC 529 1989) DIN 40050-EN 602529
Internal clock operating time	: 3 years with system not powered (unlimited with system powered)

TRANSPONDER KEY CHT 600

Temperature range	: from -40°C to + 85°C
Insulation standard	: IP67 (IEC 529 1989) DIN 40050-EN 602529
Running time	: unlimited
Code	: 2 128 combinations (double ROLLING CODE)
Event recording internal memory	: 512 BYTE



med s.p.a.
Via Raffaello, 33
42100 - Reggio Emilia (Italy)



Cod. 064.316.285 05/99

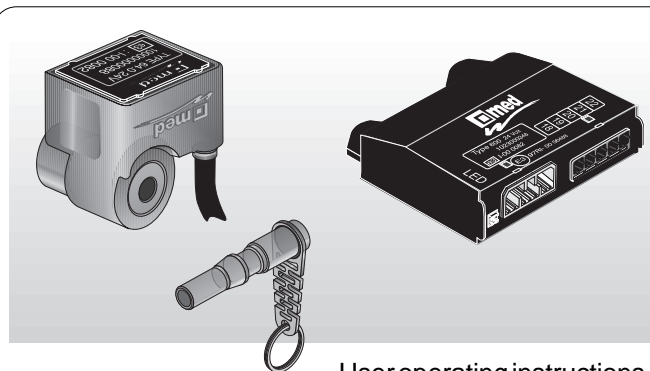

User operating instructions

med 64.0

Immobiliser system complete with transponder key with double ROLLING-CODE and event memory – 24V



064316285

CONGRATULATIONS!

Med, a leading manufacturer of car and transported goods protection devices offers you **med 64**, a new high-tech benchmark in the industry for the protection of your vehicle. This device incorporates all the top-quality features (3 years warranty), reliability and service that have always distinguished our company.

The **med 64.0** is a 24 V combined modular security system for diesel vehicles; it ensures maximum fitting flexibility and ease of use.

The **med 64.0** has been type approved according to the following standards:

- **CEI 79.17** covering immobilisers (replaces **ANIA** standard), acquiring the **IMQ** mark  for security devices and alarms with LEVEL AT3, the highest in its category;
- regulation **ECE/ONU97** no. **E3 97 RI-00 56488**;
- European directive **95/56/EC** covering operation and safety of immobilisers no. **e3 I-000082**;
- European directive **95/54/EC** covering electromagnetic disturbance.

The **med 64** system is set to dialogue with:

- **med GLOBAL** satellite system, together with which vehicle “**power reduction**” can be engaged, in case of attempted theft or break-in;
- **med** alarm units;
- supplementary immobilisers.

MAINTENANCE

The **med 64** system is maintenance free.

The **med 600** unit features a clock with its own internal sealed power battery, with an operating time (when the unit is not powered) of 3 years altogether, unlimited with unit powered.

WARRANTY CONDITIONS

The technical warranty lasts three years starting from the date of installation, ex-works, and covers all parts considered faulty according to **med's** indisputable judgement.

The warranty does not cover external labour costs and all other costs whatsoever.

The **WARRANTY** refers only to the appliances for which the special **INSTALLATION CARD** (duly completed) was received

IMPORTANT

- # Installation must be done by professional personnel interrupting the power supply and using the anti-unscrewing devices envisaged.
- # The fitter must issue the attached installation certificate duly completed and signed, as well as these operating instructions, to the owner of the vehicle.
- # **Med s.p.a.** cannot accept liability and shall suspend the warranty in the event of improper use of the product or part thereof, of tampering with the product or linking this to non-contemplated devices.

Each key also stores a consecutive number indicating the modification level undergone by the current **SET**. Because the system is “**DISENGAGED**” during **STAGE 2**, only the last key, once the procedure is correctly terminated, will provide correct system “**ENGAGED**” information.

DISCONNECTING THE VEHICLE BATTERY

No special warnings.

CONNECTING THE VEHICLE BATTERY

RECONNECT THE BATTERY TERMINALS

The **med 64** system performs an AUTOTEST every time it is switched on.

At the end of this operation (about 5 seconds), if the LED flashes slowly, the system is working correctly.

Other indications from the LED mean system faults. In this case, contact the installer or the **med** after-sales service.

Even in the event of power breaks, the system continues to store all internal data, without any type of operation being required. Furthermore, the **med 600** unit integrated clock has a max operating autonomy of 3 years **without external power supply**.

The unit consists of the following parts:

- **Main immobiliser:**
intercepts the flow of fuel at the inlet of the injection pump, to which it is irreversibly secured;
- **Med 64 system and double secondary immobiliser control unit:**
manages the entire system, features autotest functions, internal relays for two more power cuts (LEVEL AT3 according to **CEI 79.17** standard for immobilisers), with sealed internal clock for operating data storage functions;
- **Main key socket:**
contains, holds and puts in direct contact the ROLLING CODE digital electronic key with the control unit;
- **Transponder digital keys:**
special keys without contacts, very reliable, with specific ENCRYPTED code, meaning the code is processed by means of a special double ROLLING-CODE (variable code with 2^{128} available combinations). The key also features an **event memory**, meaning it stores latest operation occurrences, including the date and time.

STARTING the engine:

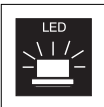
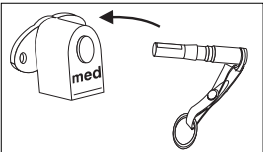
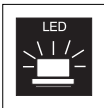
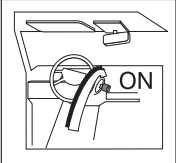
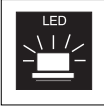
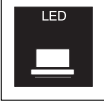
	Slow flashing	The system is correctly engaged
		Fit the med key in the socket, pressing slightly until it is fully inserted. The key will stay fixed in the socket.
	Quick flashing	The LED will start flashing quickly, meaning the key has been inserted correctly. To remove this from the socket without starting the engine, simply press it again as far as it will go.
		Turn the ignition key to ON , without starting the engine again
	On (permanent)	The LED will stay on permanently during the authorisation stage and then go off upon recognition (about 2 seconds)
	Off	Wait for the LED to go off, accompanied by an audible chirp, and START THE ENGINE

THE ENGINE IS NOW ON

Once the engine has been started, the key cannot be removed from the ignition

STAGE 2 (storage):

- Refit the **FIRST** of the new keys inserted at **stage 1**.
- Refit all the keys used in STAGE 1 (new and old), not necessarily in the previous sequence. DETAILS of the new SET will be updated on each key. During the key re-writing stage the LED remains permanently on.
- The last fitted key remains fast in the socket and the LED goes off (as in normal operation mode) until the ignition key is turned to "**OFF**". At this point, the new valid SET of keys has been created.

IMPORTANT: During STAGE 1, the procedure can be interrupted by simply turning the ignition key to "**OFF**", in the event of a wrong operation being performed or to stop the procedure. During STAGE 2, the procedure cannot be interrupted without risking the permanent disengagement of the entire system.

In case of doubt or difficulty, immediately contact the installer or the **med** after-sales service.

At the end of the procedure, the **SET** of keys will have been **modified**. Unless one of the keys of the old **SET** has been inserted, this will be automatically **DISABLED**.

ADDING OR REPLACING KEYS

The **med 64** system is complete with already activated keys. In the event of a **CHT 600** immobiliser key being lost or to increase the number of keys, one or more additional virgin keys can be acquired through the **med** installer.

The system can manage up to 8 keys at the same time.

Keys belonging or which have belonged to other **med 64** systems cannot be used.

For safety reasons, the key replacement/addition procedure calls for possession of all original keys (valid SET), or of all these except one. It is therefore most important to promptly replace any lost keys to once more complete a valid SET, consisting of at least THREE keys and maintain the system's operating data storage function.

Procedure :

TURN THE IGNITION KEY TO "ON" (IGNITION ON):

STAGE 1 (learning):

- Insert the new key to be stored.
After reading, the key will detach from the socket and the LED will start flashing quickly
- Insert any other new keys to be stored.
- Insert all the keys (to be kept active) of the old SET in sequence, waiting each time for these to detach. Every time key reading terminates, a short audible chirp is heard and the LED starts flashing quickly again

Engine STOP and automatic immobiliser switch-on

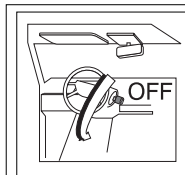

Turn the ignition key to **OFF**

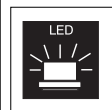

On (permanent)

The LED stays on permanently

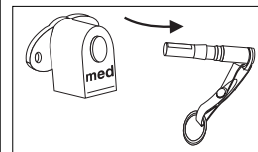

After about **2 seconds**, the **med** key detaches slightly.

The immobiliser has switched on automatically

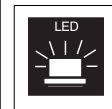

Slow flashing

The LED begins to flash again slowly

THE IMMOBILISER IS NOW ENGAGED

LED ALWAYS ON: fault (see next page)

Following a wrong operation or fault, the key might not be released and the LED will stay on permanently. **TO FORCE RELEASE:**

Switch the vehicle ignition key on and off 10 consecutive times, turning this in rapid sequence (**+15 ON, +15 OFF**). After this, the **med** key will be released.

If this happens again, contact the **med** after-sales service.

TROUBLESHOOTING

● MANUAL KEY READING

If the LED does not flash quickly when the **med** key is inserted, keep the LED pressed for at least **two seconds** in order to complete the “manual key reading” operation.

IMPORTANT: If the problem reoccurs, contact a **med** after-sales centre to restore the system.

● FULL KEY INSERTION

If, with the med key in the socket and turned **+15** in **ON**, the engine **DOES NOT START**, the LED flashes **three** times and a chirp is heard **three** times in continuous sequence, push the key in as far as it will go to ensure correct insertion.

● FAULT CONDITION

During normal operation, the **med 600** unit performs complete internal and peripheral monitoring. If any problems are found in the system, this switches to fault condition:

The FAULT condition is indicated by the permanent lighting up of the LED.

What is more, 2 or 3 seconds after the engine is switched off:

- **4 to 7 chirps** are heard, instead of the usual chirp;
- the LED remains permanently on, instead of flashing slowly;
- **the key remains in the socket** only if the fault involves the **main IMMOBILISER**.

Only in this latter case will it be necessary to re-insert the ignition key (**+15 ON**) and press the key (in the socket) or the LED/BUTTON as far as these will go in order to restart the engine.

In all other cases, the engine can be started normally.

IMPORTANT:

In **FAULT** condition, **the key also records this information**.

To exit from fault condition and ensure correct key recordings, switch the ignition key on and off 10 times altogether (**+15 ON + 15 OFF**):

- the LED goes off;
- **3 chirps** are heard;
- the system begins operating normally again

If the FAULT persists or returns, the previously mentioned signals will be repeated; in this case, contact the installer or **med** after-sales service.

IMPORTANT:

Exit from the FAULT condition to maintain key operating data storage.

● LEAVING THE med KEY IN THE SOCKET

LED permanently on and continuous **CHIRP** every time the door is opened after the engine is stopped.

IMPORTANT: If, after inserting the **med** key, the engine is **NOT** started within **5 minutes**, the key is automatically released.