

[med]

“Mercedes ATEGO”

med 75.03.09

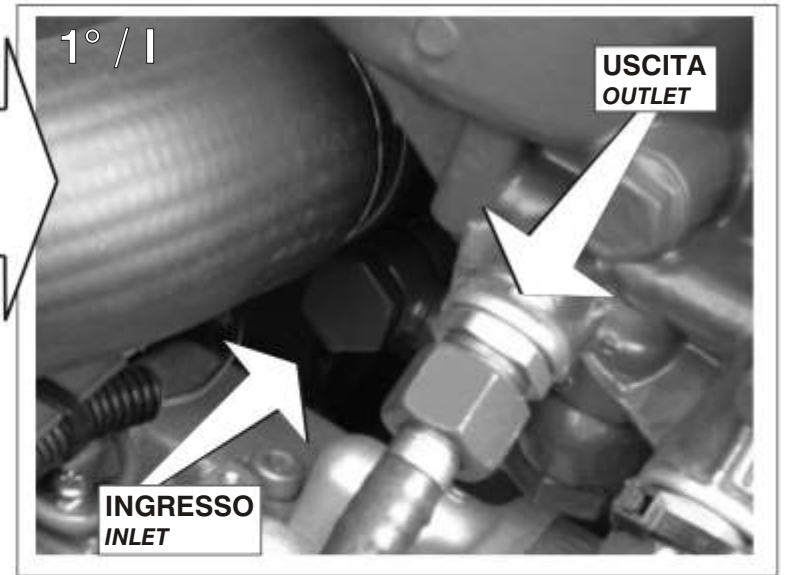
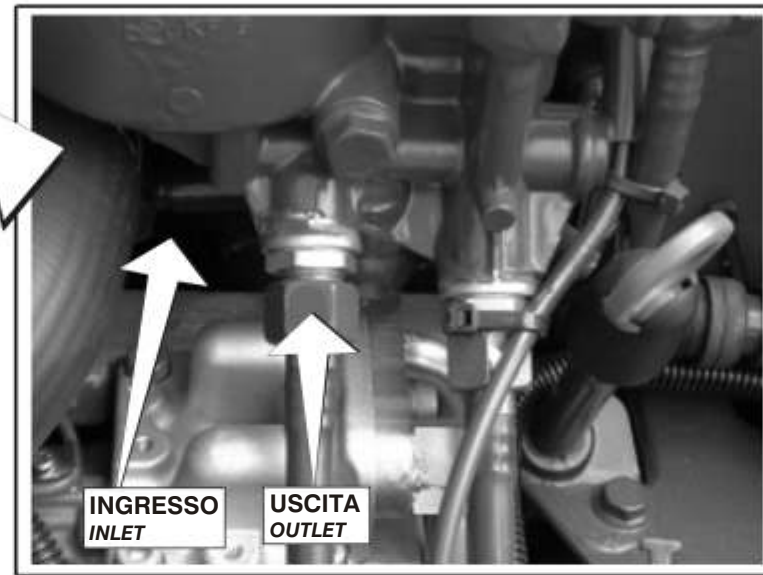
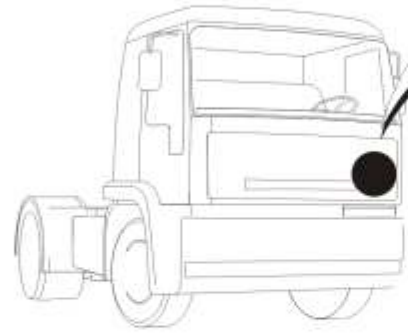

INGRESSO / INLET

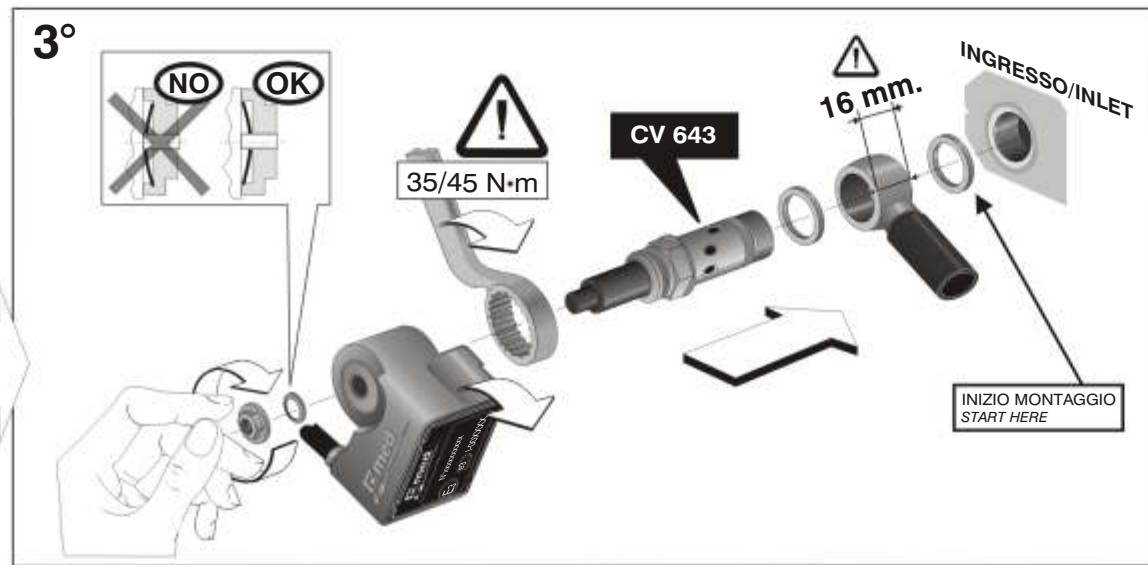

TEST



VERIFICA DELL'IMPIANTO
System check



USCITA / OUTLET

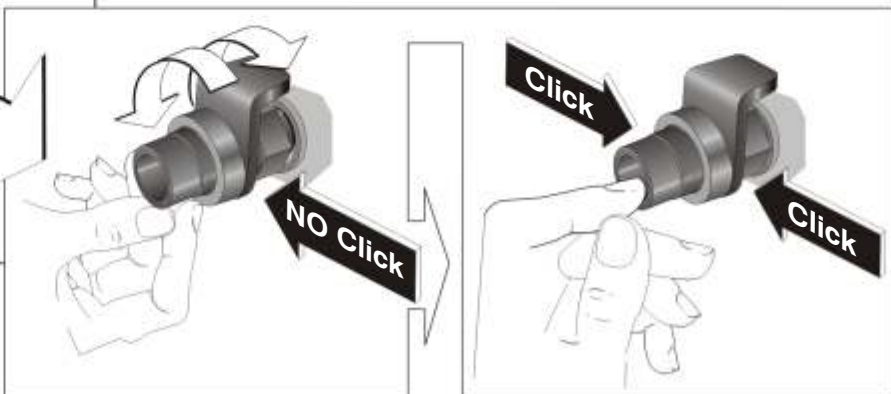
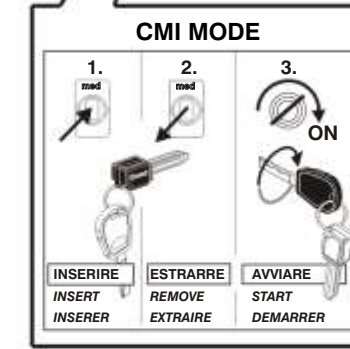
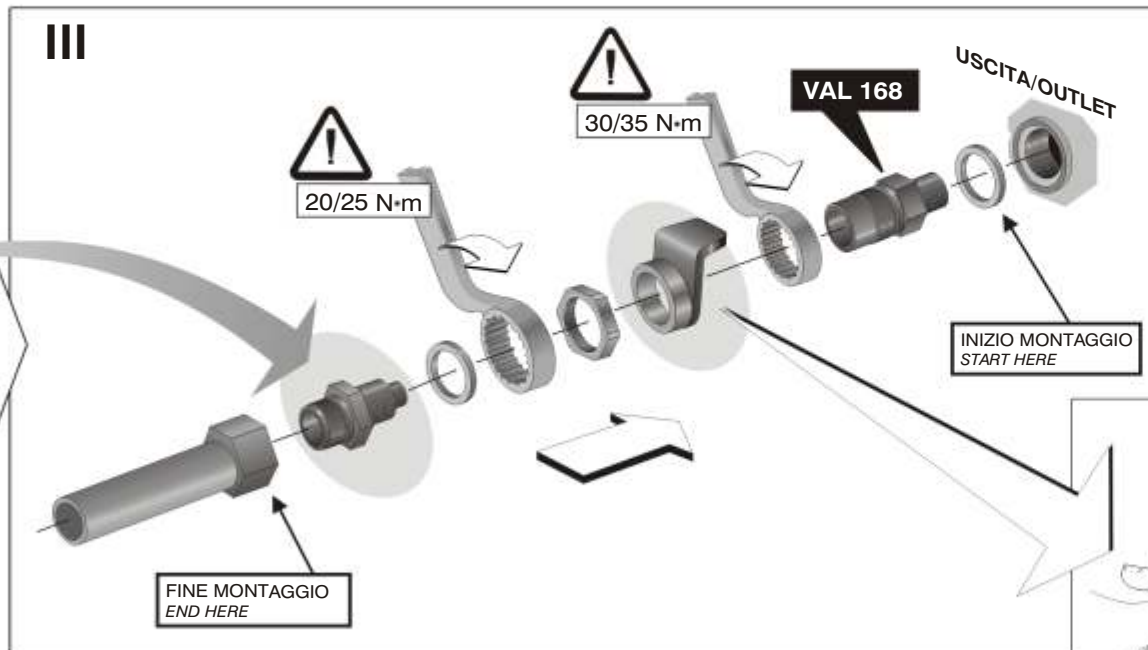

[med]

med S.p.A.
Via Raffaello, 33 - 42100 Reggio Emilia (Italy)
tel. +39 0522 511665 fax +39 0522 500153

www.med-italy.com
e-mail: med.service@med-italy.com



AZIENDA CON SISTEMA QUALITÀ
CERTIFICATO DA DNV
UNI EN ISO 9001

med 75.03.09

COLLEGAMENTO SU "Mercedes ATEGO" CONNECTION ON

■ **ATTENZIONE:** Il colore e la posizione dei fili originali sono da ritenersi puramente indicativi, poiché possono verificarsi variazioni ad opera della casa costruttrice.

■ **WARNING:** Color and position of vehicle original wire are to be considered approximate, as some changes may be done by the manufacturer.

