



DAF con "INIETTORE / POMPA"  
DAF with "PUMP INJECTOR"

med 75.07.8C



750315475

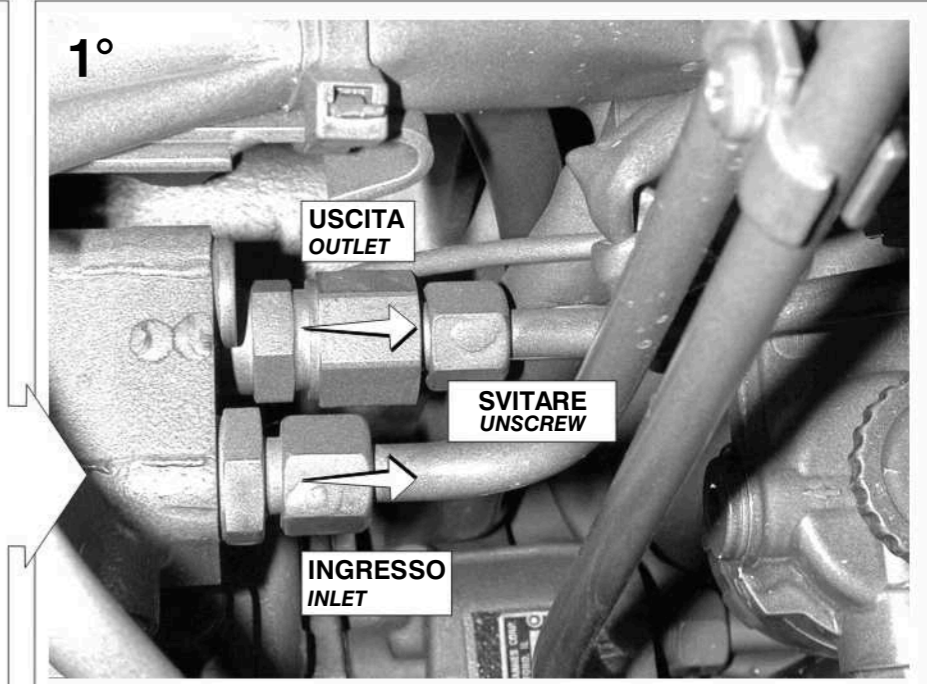
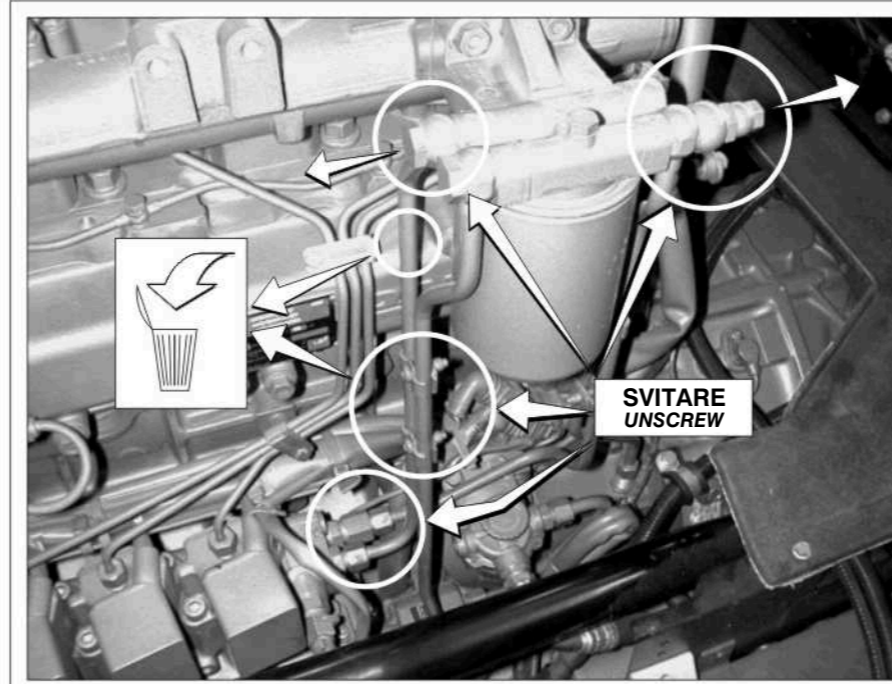
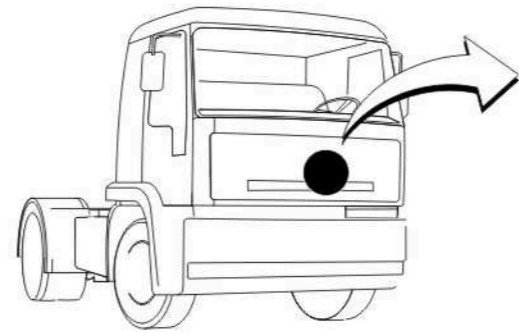

- SOSTITUIRE I TUBI ORIGINALI DI INGRESSO/USCITA GASOLIO CON I TUBI FORNITI IN CONFEZIONE
- REPLACE THE ORIGINALS DIESEL OIL INLET AND OUTLET PIPES WITH THE ONES SUPPLIED IN THE PACKAGE

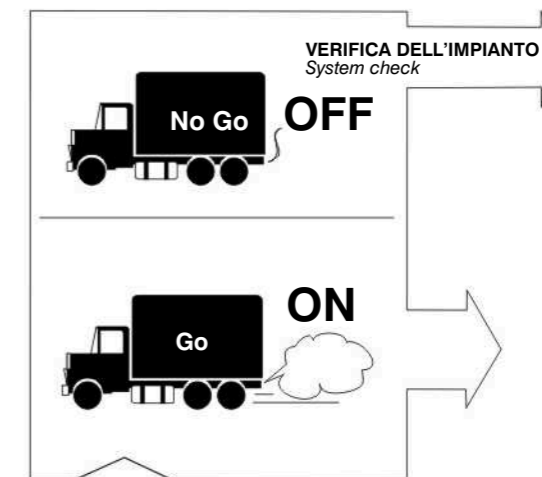
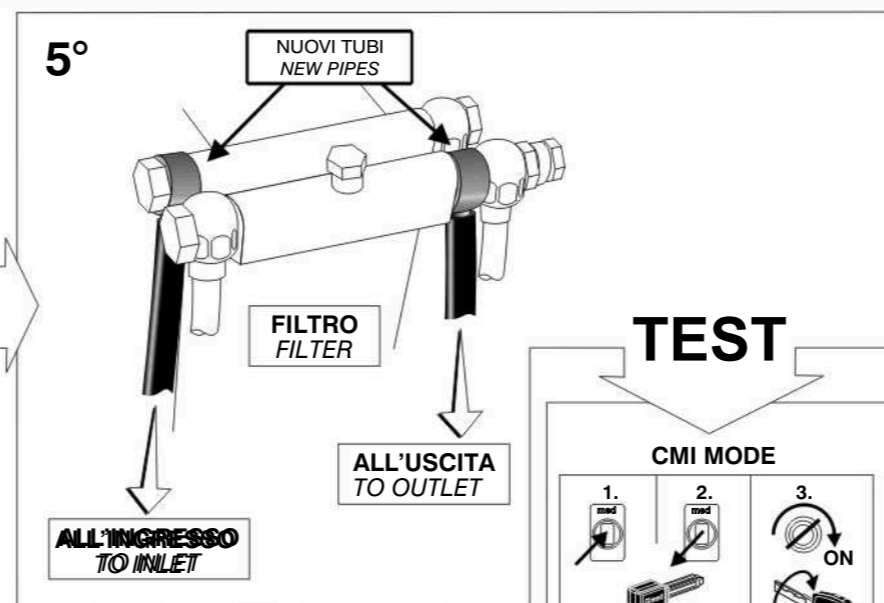
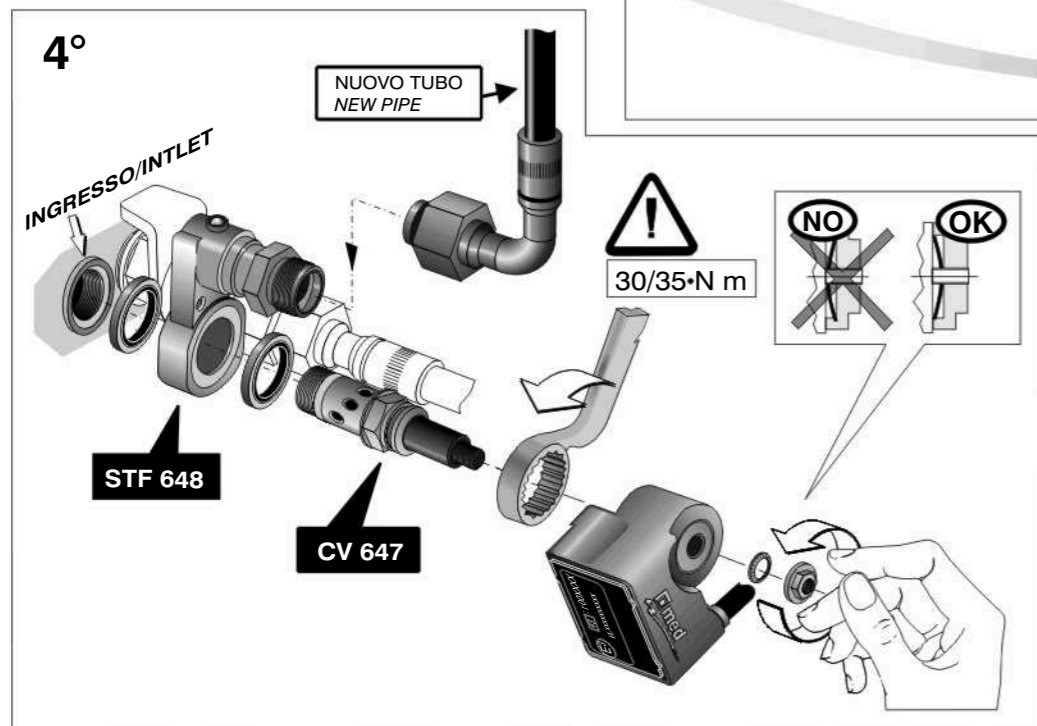
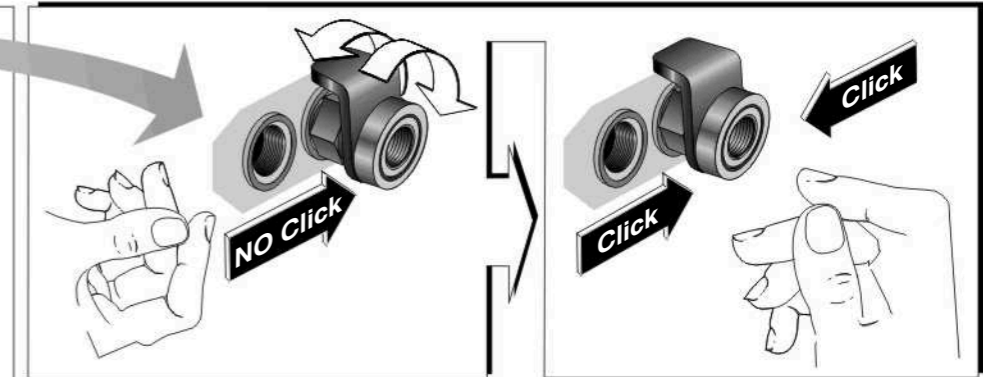
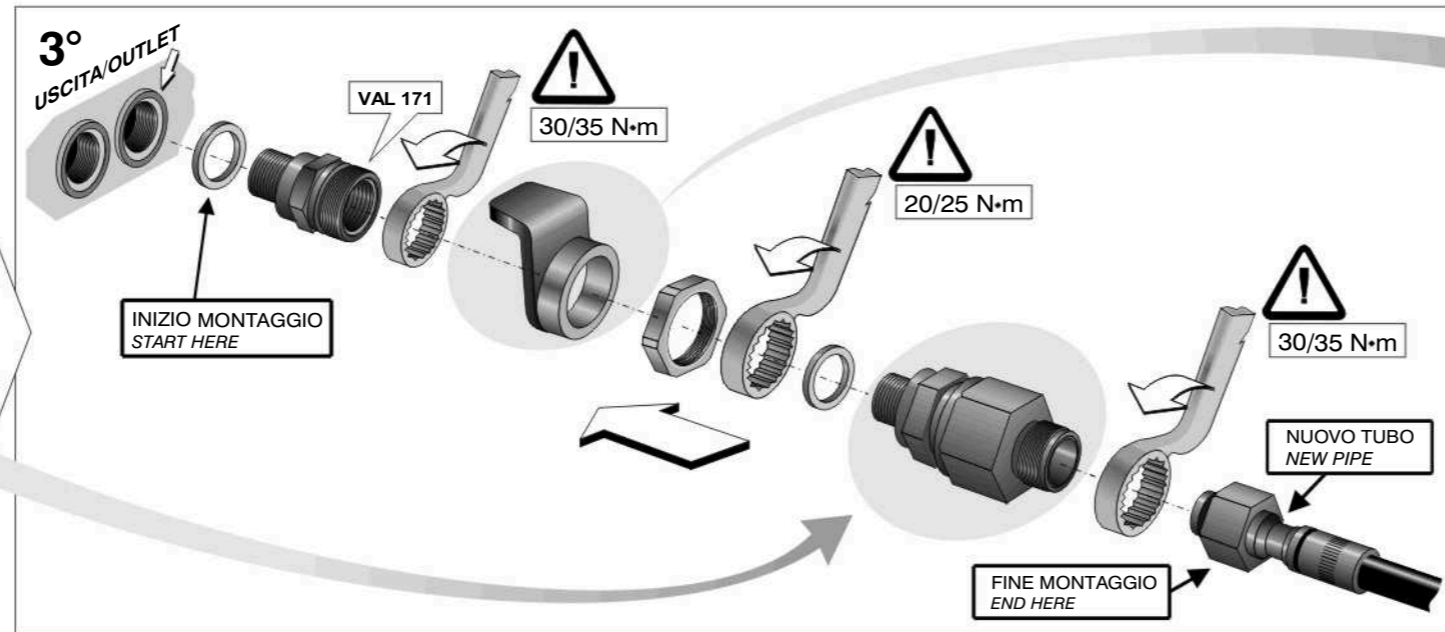
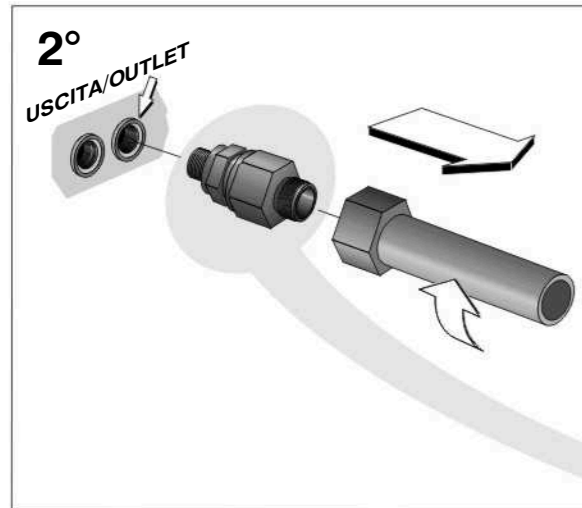

**TEST**

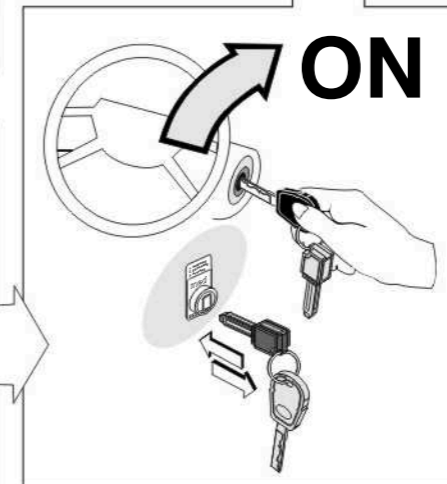
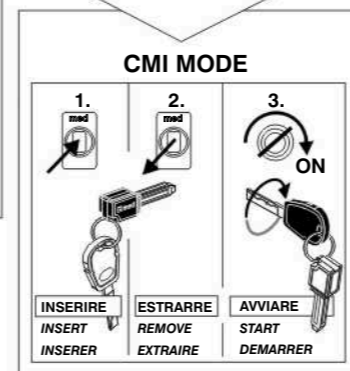

**[med]** med S.p.A.  
Via Raffaello, 33 - 42100 Reggio Emilia (Italy)  
tel. +39 0522 511665 fax +39 0522 500153

www.med-italy.com  
e-mail: med.service@med-italy.com

