

[med]

med 75.05.03

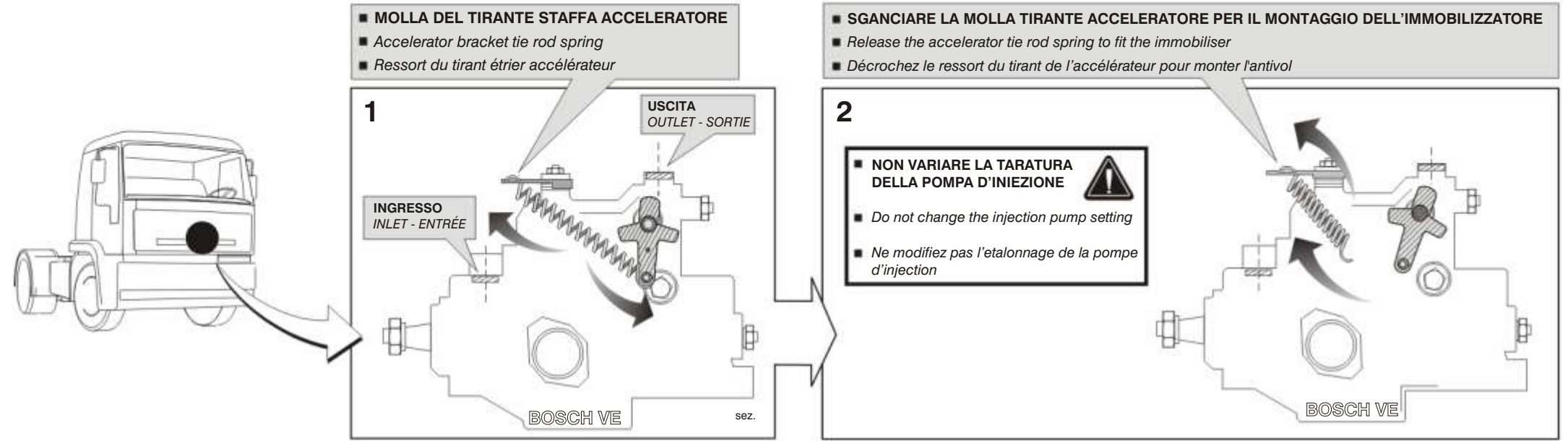

IVECO E12 - E14 - E15 - E18 - E21



INGRESSO
INLET - ENTRÉE

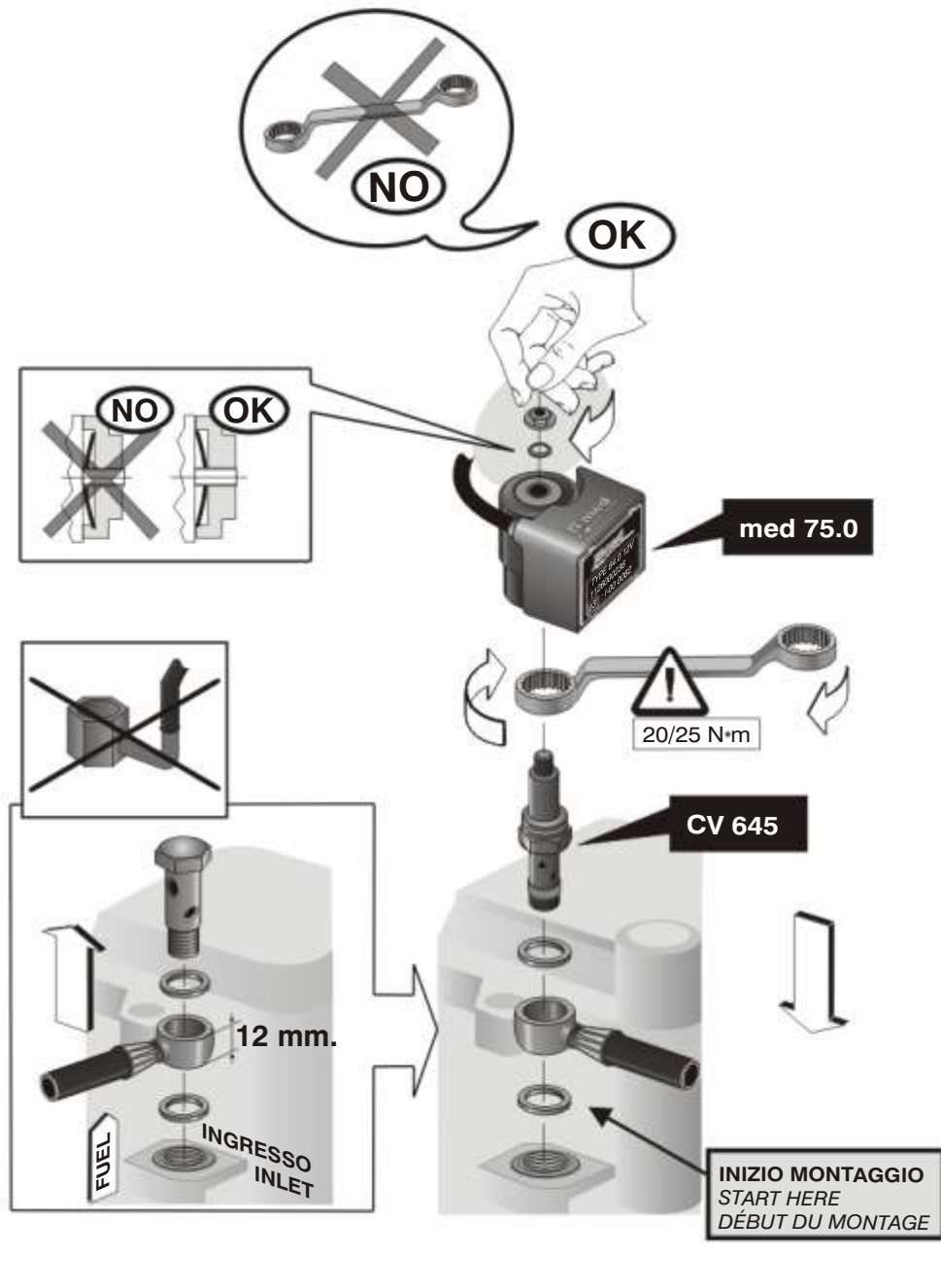

3

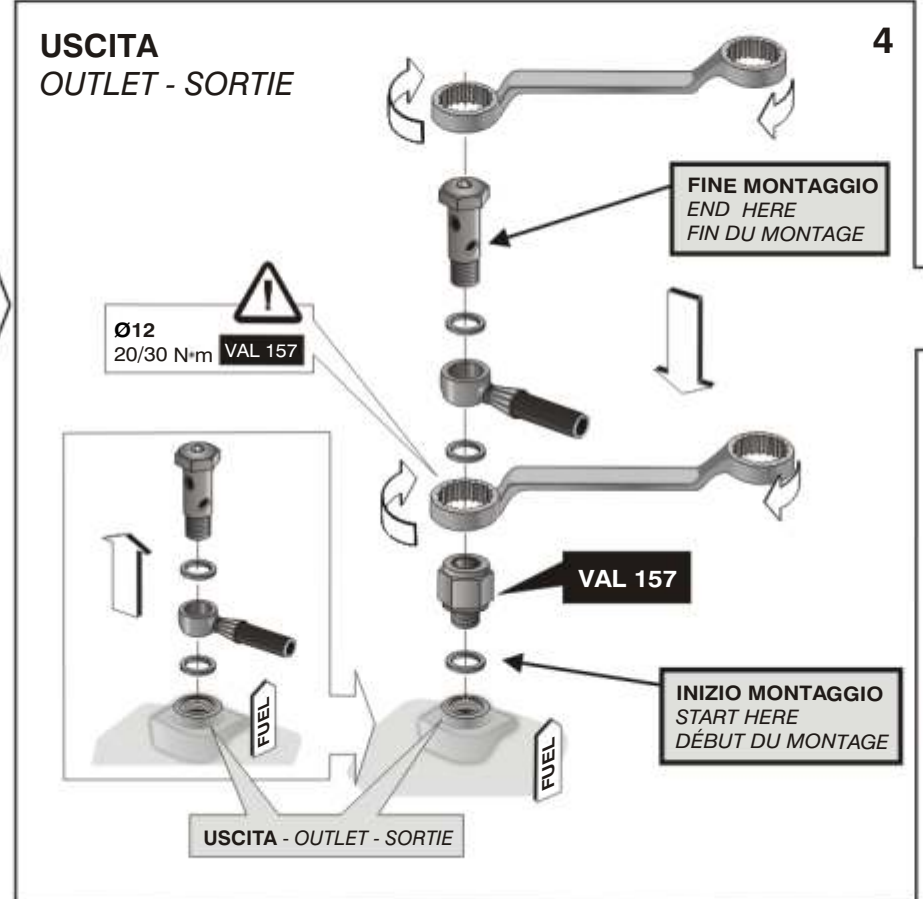

4

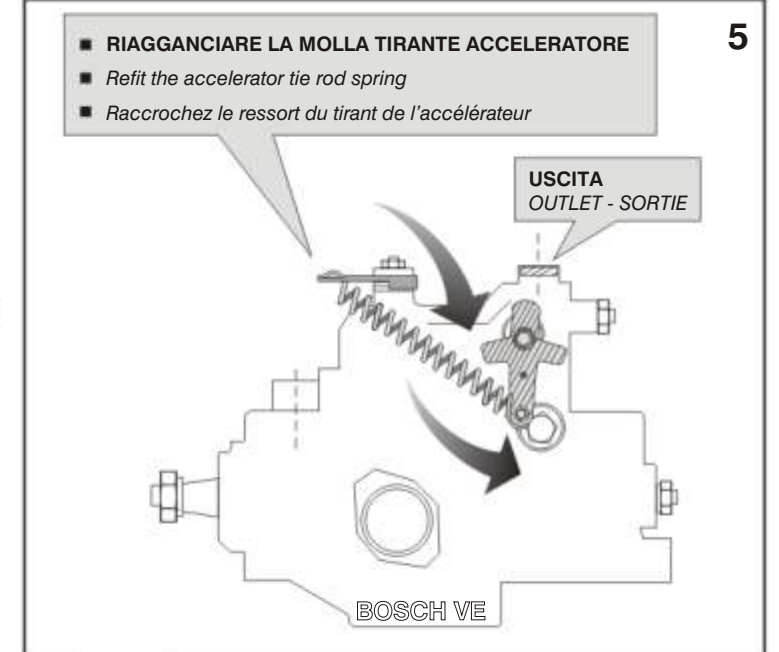

5

TEST

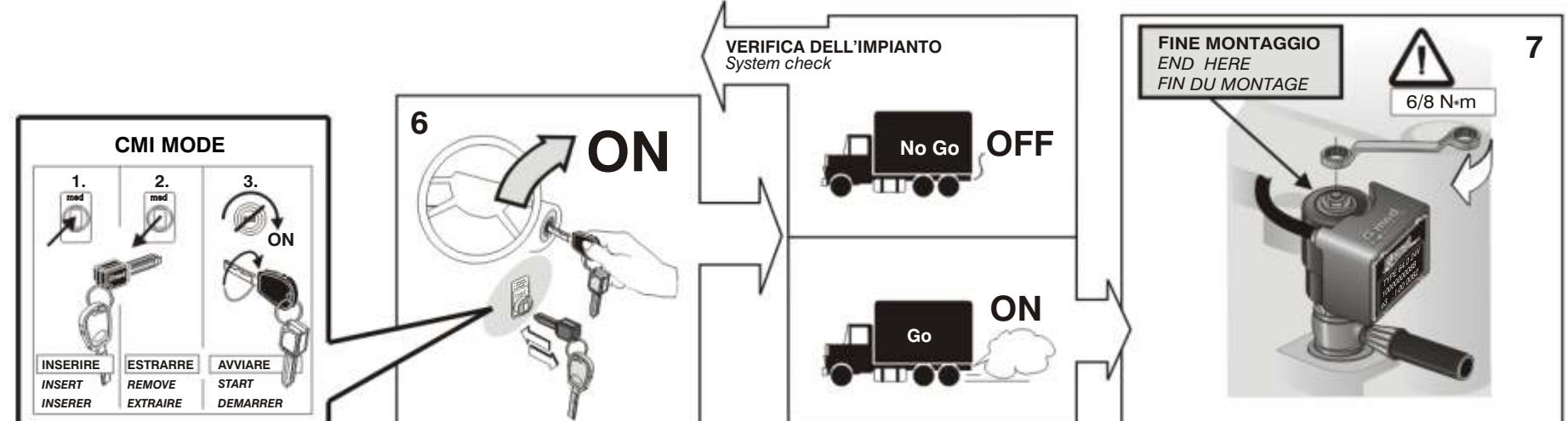

6

7

[med]

med 75.05.03



750315463



IVECO E12 - E14 - E15 - E18 - E21

COLLEGAMENTO CON ACCESSO A CHIAVE

connection by key / connexion avec accès à la clé

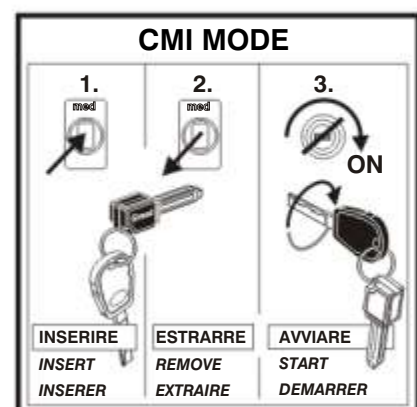

med 350.2

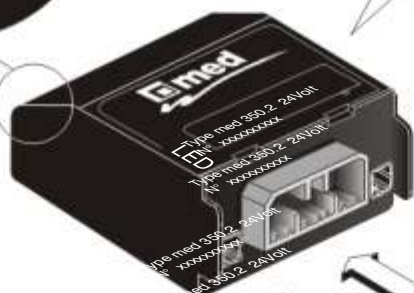

CAV 1001

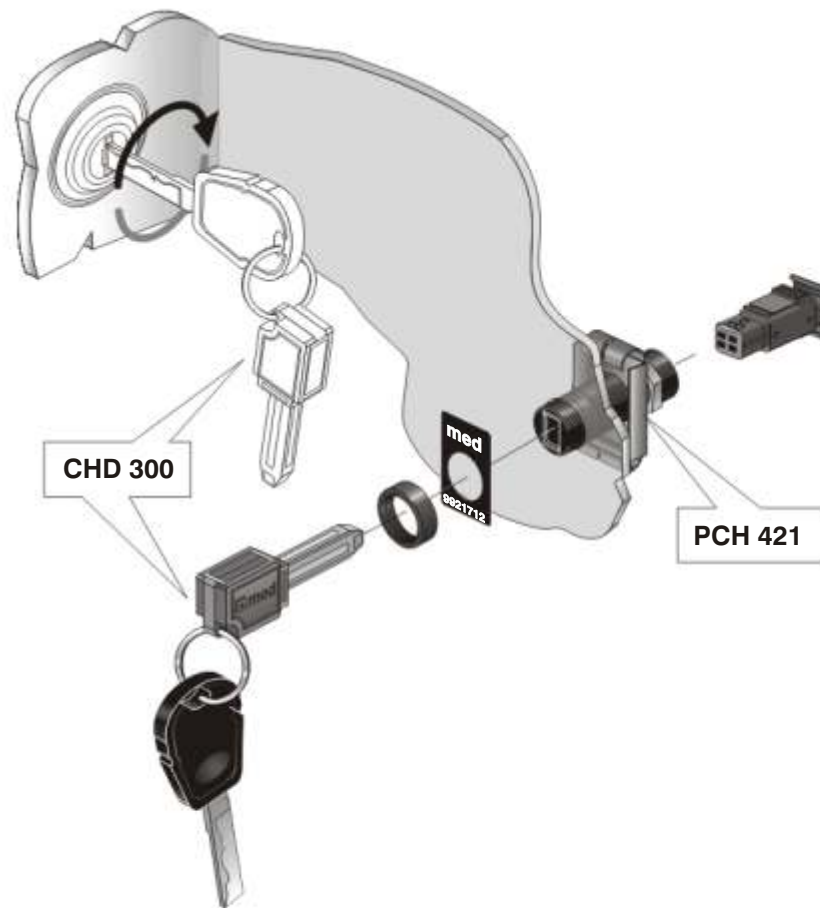

CHD 300

PCH 421

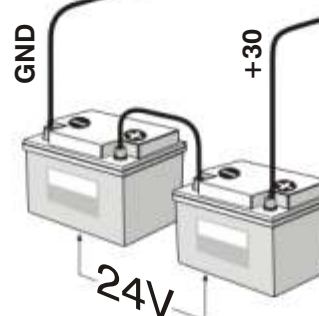

GND

+30

+15

24V

CAV 640



Click

CAV 300/N



Valvola CV 645
Valve / Soupape

med 75.0

USCITA NEGATIVA DI "STATO" - 700 mA MAX con +15 ON
ISOLARE SE NON UTILIZZATO

NEGATIVE "STATE" output - 700 mA MAX with +15 ON
INSULATE IF NOT USED

Sortie NEGATIVE d'"ETAT" - 700 mA MAX avec +15 ON
ISOLER SI N'UTILISE PAS

8

IN 2

OUT 2/MUX

Relè 2ª interruzione
2nd. break relay
Relais 2ª interruption

10A ⚠
30A 10 sec.

CONTATTO NC
NC CONTACT / CONTACT NC

FILO ROSA 9903 DIETRO ALLA SCATOLA FUSIBILI - CONNETTORE GIALLO A 12 POLI - PIN N. 1.

PINK WIRE 9903 BEHIND THE BOX FUSES, CONNECTOR YELLOW 12 POLES - PIN N. 1.

FIL ROSE 9903 DERRIÈRE LA BOÎTE FUSIBLES, CONNECTEUR JAUNE AUX 12 PÔLES - PIN N. 1.

RELÈ ORIGINALE
Original relay / Relais original

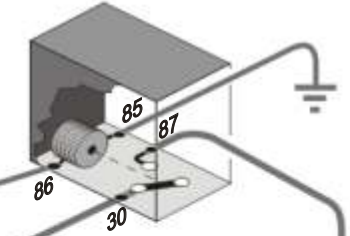

Relè 1ª interruzione
1st. break relay
Relais 1ª interruption

10A ⚠
30A 10 sec.

CONTATTO NC
NC CONTACT/CONTACT NC

MOTORINO D'AVVIAMENTO
Starter motor / Moteur de démarrage

FILO VERDE 8888 DIETRO ALLA SCATOLA FUSIBILI - CONNETTORE GIALLO A 12 POLI - PIN N. 6.

GREEN WIRE 8888 BEHIND THE BOX FUSES, CONNECTOR YELLOW 12 POLES - PIN N. 6.

FIL VERT 8888 DERRIÈRE LA BOÎTE FUSIBLES, CONNECTEUR JAUNE AUX 12 PÔLES - PIN N. 6.

[med]

med S.p.A.
Via Raffaello, 33 - 42100 Reggio Emilia (Italy)
tel. +39 0522 511665 fax +39 0522 500153

www.med-italy.com
e-mail: med.service@med-italy.com



AZIENDA CON SISTEMA QUALITÀ CERTIFICATO DA DNV
UNI EN ISO 9001